

# PRODUCT SPECIFICATIONS

For Customer: \_\_\_\_\_

: APPROVAL FOR SPECIFICATION

Customer Model No. \_\_\_\_\_

: APPROVAL FOR SAMPLE

Module No.: GZ70204-DIT084XG

Date : 2023.12.26

## Table of Contents

No.	Item	Page
1	Cover Sheet(Table of Contents)	P1
2	Revision Record	P2
3	General Specifications	P3
4	Outline Drawing	P4
5	Absolute Maximum Ratings	P5
6	Electrical Specifications	P6-P12
7	Optical Characteristics	P13-P16
8	Reliability Test Items and Criteria	P17
9	Precautions for Use of LCD Modules	P18-P19

## For Customer's Acceptance:

Approved By	Comment

PREPARED	CHECKED	APPROVER
YZJ		

**2. Revision Record**

Date	Rev.No.	Page	Revision Items	Prepared
2023.8.10	V0		The first release	YZJ

### 3. General Specifications

GZ70204-DIT084XG is a TFT-LCD module. It is composed of a TFT-LCD panel, driver IC, FPC, a back light unit. The 8.0'' display area contains 1024x768 pixels and can display up to 16.7M colors. This product accords with RoHS environmental criterion.

Item	Contents	Unit	Note
LCD Type	TFT	-	
Display color	16.7M		
Viewing Direction	ALL	O'Clock	
Operating temperature	-30~+80	°C	
Storage temperature	-30~+80	°C	
Module size	199.50X149.00X10.2	mm	
Active Area(W×H)	170.496X127.872	mm	
Number of Dots	1024x768	dots	
Driver IC	HX8290*2+HX8695	-	
Power Supply Voltage	3.3	V	
Outline Dimensions	Refer to outline drawing	-	
Interface	8bits - LVDS	-	

## 4.Outline.Drawing

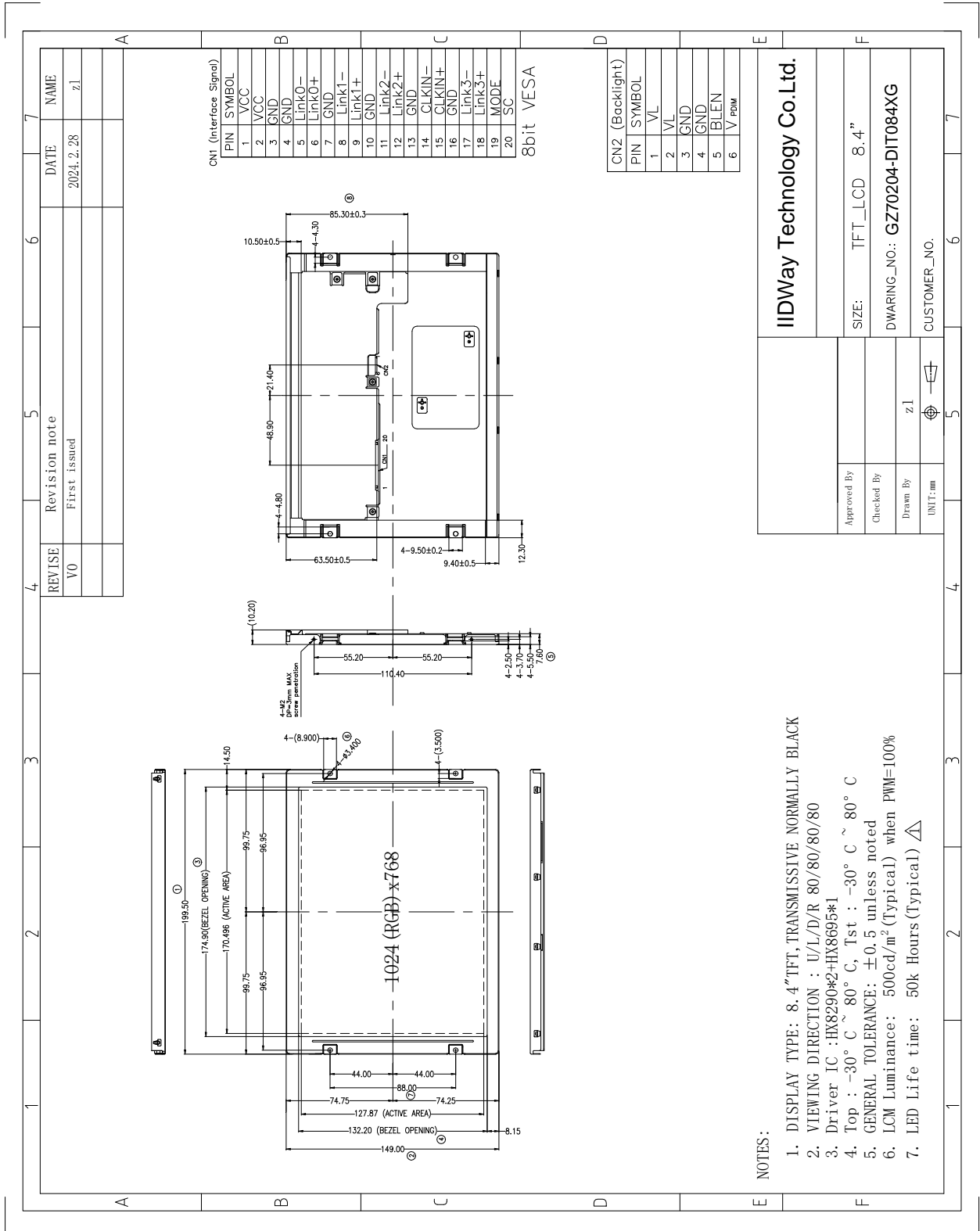

## 5. Absolute Maximum Ratings( $T_a=25^\circ\text{C}$ )

### 5.1 Electrical Absolute Maximum Ratings.( $V_{SS}=0\text{V}$ , $T_a=25^\circ\text{C}$ )

Item	Symbol	Min.	Max.	Unit	Note
Power Supply Voltage	VCC	-0.3	4.0	V	1, 2
	VL	-0.3	14.0	V	1, 2
	VPDIM	-0.3	14.0	V	1, 2
	BLEN	-0.3	14.0	V	1, 2

Notes:

1. If the module is above these absolute maximum ratings. It may become permanently damaged.  
Using the module within the following electrical characteristic conditions are also exceeded, the module will malfunction and cause poor reliability.
2.  $V_{CC} > V_{SS}$  must be maintained.
3. Please be sure users are grounded when handing LCD Module.

### 5.2 Environmental Absolute Maximum Ratings.

Item	Storage		Operating		Note
	MIN.	MAX.	MIN.	MAX.	
Ambient Temperature	$-30^\circ\text{C}$	$80^\circ\text{C}$	$-30^\circ\text{C}$	$80^\circ\text{C}$	1,2
Humidity	-	-	-	-	3

1. The response time will become lower when operated at low temperature.
2. Background color changes slightly depending on ambient temperature.  
The phenomenon is reversible.
3.  $T_a \leq 40^\circ\text{C}$ : 85%RH MAX.  
 $T_a > 40^\circ\text{C}$ : Absolute humidity must be lower than the humidity of 85%RH at  $40^\circ\text{C}$ .

## 6. Electrical Specifications

### 6.1 Electrical characteristics for LCD( $V_{SS}=0V, T_a=25^\circ C$ )

Parameter	Symbol	Condition	Min	Typ	Max	Unit	Note
Power supply	VCC	$T_a=25^\circ C$	2.7	3.3	3.6	V	
Backlight Power supply	VL	$T_a=25^\circ C$	9	12.0	13.2	V	
Input voltage	'H'	$V_{IH}$	$0.7V_{CC}$	-	VCC	V	
	'L'	$V_{IL}$	-0.3	-	$0.3V_{CC}$	V	
Current of power supply	ICC	$T_a=25^\circ C$	-	180	-	mA	

### 6.2 LED backlight specification( $V_{SS}=0V, T_a=25^\circ C$ )

Item	Symbol	Min	Typ	Max	Unit	Note	
Supply voltage	VL	9	12.0	13.2	V		
Supply Current	IL	-	350	-	mA	(VL=12V) PWM=100%	
Power Consumption	PL	-	4.2	-	W	(VL=12V) PWM=100%	
PWM Control Frequency	$F_{PDIM}$	100	-	30K	Hz		
Backlight ON-OFF	High	BLEN	1.6	-	VL	V	
	Low		0	-	0.8	V	
PWM Control Level	High	$V_{PDIM}$	1.6	-	VL	V	
	Low		0	-	0.8	V	
Uniformity	$\Delta Bp$	75	80	-	%		
Life Time	time	-	50K	-	hours	1	

Note 1: Brightness to be decreased to 50% of the initial value at ambient temperature  $T_a=25^\circ C$

**6.3 Interface signals****6.3.1 LCM PIN**

Pin No.	Symbol	I/O	Function
1-2	VCC	P	Power supply
3-4	GND	P	Ground.
5	LINK0-	I	LVDS lane0 input
6	LINK0+	I	
7	GND	P	Ground.
8	LINK1-	I	LVDS lane1 input
9	LINK1+	I	
10	GND	P	Ground.
11	LINK2-	I	LVDS lane2 input
12	LINK2+	I	
13	GND	P	Ground.
14	CLKIN-	I	LVDS CLK input
15	CLKIN+	I	
16	GND	P	Ground.
17	LINK3-	I	LVDS lane3 input
18	LINK3+	I	
19	MODE	-	Not connection
20	SC	I	Scan direction control (Low=Normal, High=Reverse)

## 6.3.2 CN 2(Backlight)

Backlight-side connector: FI-S6P-HFE (JAE)

Corresponding connector: FI-S6S (JAE)

Pin No.	Symbol	I/O	Function
1-2	VL	P	Power supply For BL.
3-4	GND	P	Ground.
5	BLEN	I	LED driver enable input
6	VPDIM	I	PWM dimming control input.

## 6.4 Power and signals sequence

- |   |                          |
|---|--------------------------|
| $0.1 \text{ ms} \leq t1 \leq 10 \text{ ms}$ | $200 \text{ ms} \leq t4$ |
| $0 \leq t2 \leq 50 \text{ ms}$              | $200 \text{ ms} \leq t5$ |
| $0 < t3 \leq 50 \text{ ms}$                 | $0 \leq t6$              |

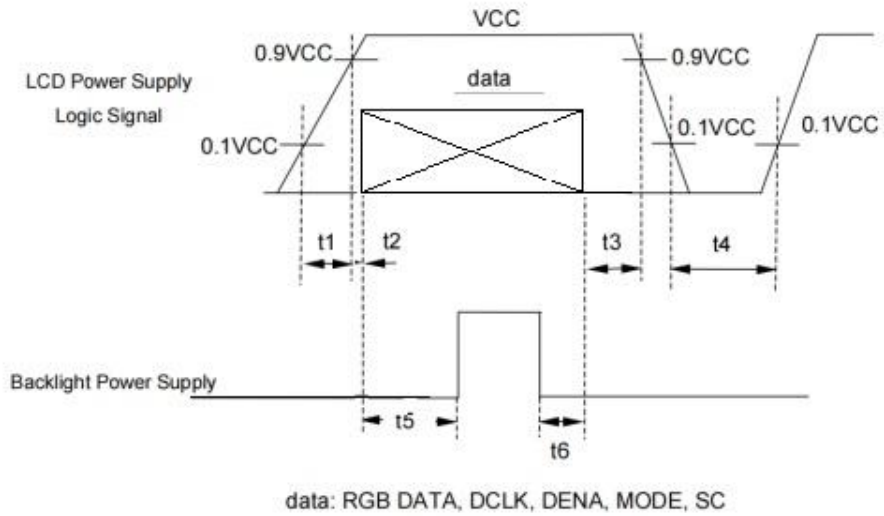

VCC-dip conditions:

- 1) When  $2.6 \text{ V} \leq VCC < 3.0 \text{ V}$ ,  $t_d \leq 10 \text{ ms}$
- 2) When  $VCC < 2.6 \text{ V}$

VCC-dip conditions should also follow the power and signals sequence.

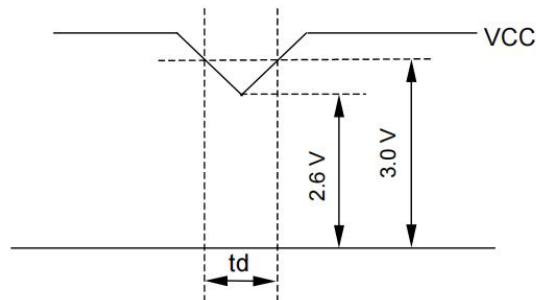

## 6.5 AC Characteristics

### 6.5.1 For the digital circuit: LVDS mode

Parameter	Symbol	Condition	Spec.			Unit
			Min.	Typ.	Max.	
Differential input high Threshold voltage	$V_{th}$	$V_{cm}=1.2V$	-	-	+0.1	V
Differential input low threshold voltage	$V_{tl}$	-	-0.1	-	-	V
Differential input common Mode voltage	$V_{CM}$	-	1	1.2	$1.7- V_{id} /2$	V
LVDS input voltage	$V_{INLV}$	-	0.7	-	1.7	V
Differential input voltage	$ V_{id} $	-	0.1	-	0.6	V
Differential input leakage Current	$I_{lvleak}$	-	-10	-	+10	$\mu A$

**Single-ended:**  
 LVCLKP(R),  
 LVCLKN(R),  
 LVD[3:0]P(R),  
 LVD[3:0]N(R)

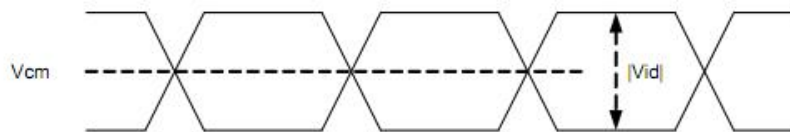

**Differential:**  
 LVCLKP(R)-LVCLKN(R),  
 LVD[3:0]P(R)-  
 LVD[3:0]N(R)

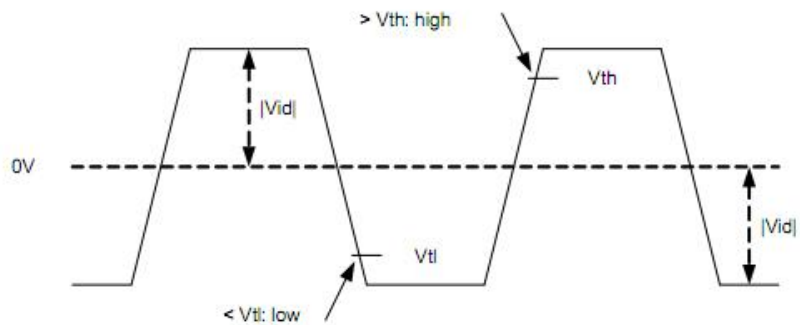

## 6.5.2 Input timing table

Parameter	Symbol	Spec.			Unit
		Min.	Typ.	Max.	
DCLK frequency	F <sub>DCLK</sub>	49	50	73.6	MHz
Horizontal valid data	thd	1024			DCLK
Hsync pulse width	thpw	10	12	255	DCLK
Hsync back porch	thbp	5	16	255	DCLK
Hsync front porch	thfp	24	26	260	DCLK
1 Horizontal line	th	1053	1066	1331	DCLK
Vertical valid data	tvd	768			H
Vsync pulse width	tvpw	1	3	20	H
Vsync back porch	tvbp	2	5	255	H
Vsync front porch	tvfp	5	8	260	H
1 Vertical field	tv	775	781	921	H
Frame rate	FR	60			Hz

### • Horizontal

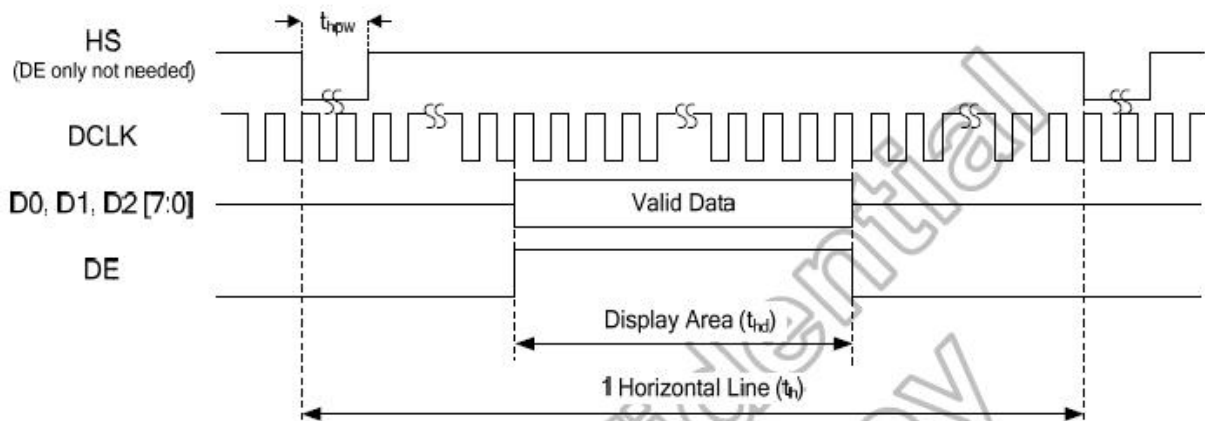

### • Vertical

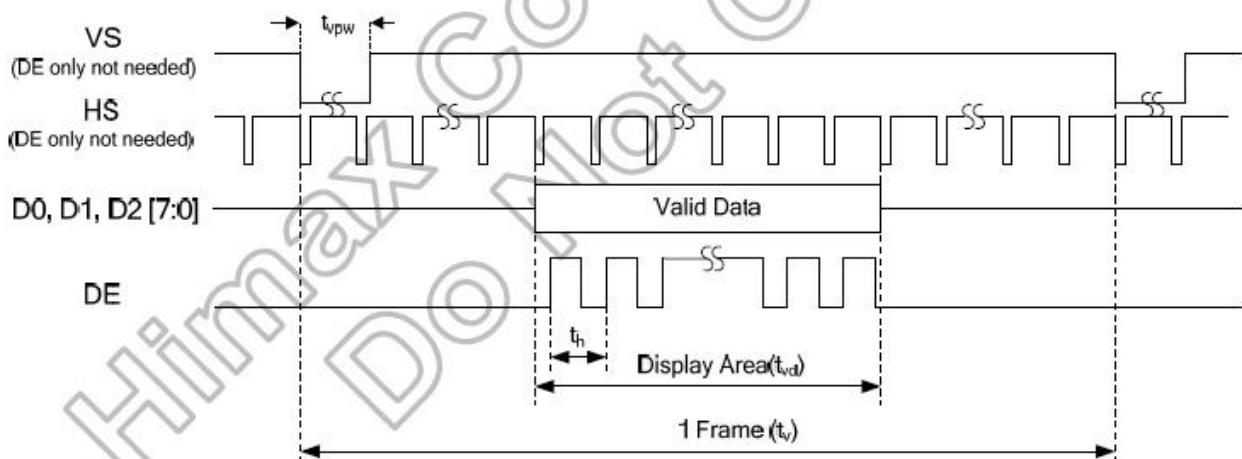

## 6.6 Reset timing

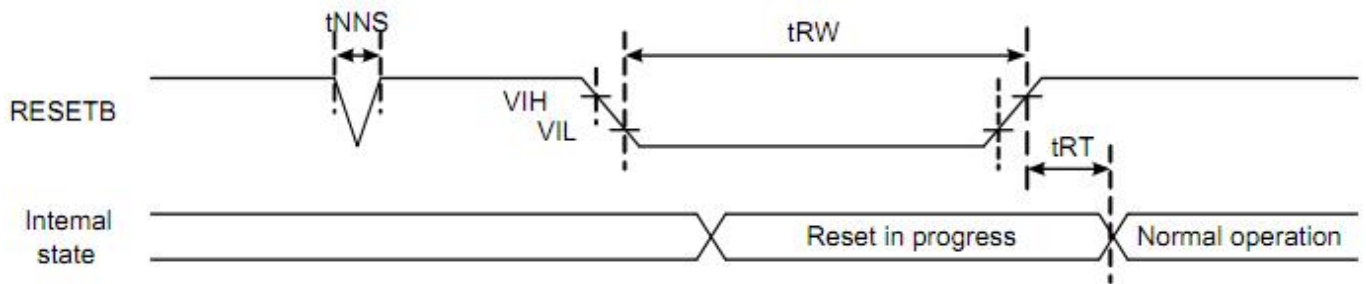

Signal	Parameter	Symbol	Spec.			Unit
			Min.	Typ.	Max.	
RESETB	Reset pulse width	tRW	10	-	-	μs
	Reset complete time	tRT	-	-	5	μs
	Negative spike noise width	tNNS	-	-	100	ns

## 6.7 LVDS interface data format

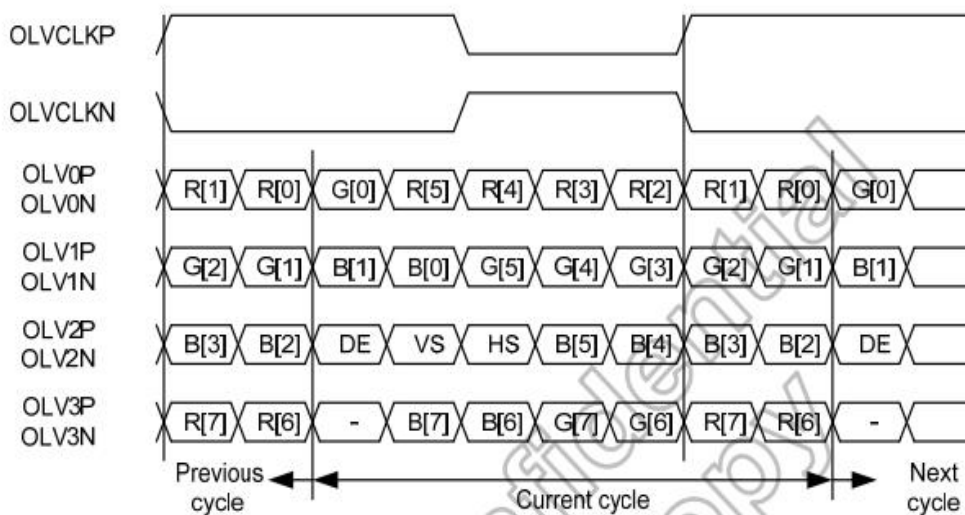

8bit mode

## 7. Optical Characteristics

Item	Symbol	Condition	Min.	Typ.	Max.	Unit	Note	
Brightness	Bp	$\theta=0^\circ$	-	500	-	Cd/m <sup>2</sup>	1	
Uniformity	$\Delta Bp$	$\Phi=0^\circ$	75	8/0	-	%	1,2	
Viewing Angle	3:00	Cr $\geq$ 10	75	80	-	Deg	3	
	6:00		75	80	-			
	9:00		75	80	-			
	12:00		75	80	-			
Contrast Ratio	Cr	$\theta=0^\circ$	800	1000	-	-	4	
Response Time	T <sub>r</sub> +T <sub>f</sub>	$\Phi=0^\circ$	-	22	25	ms	5	
Color of CIE Coordinate	W	x	$\theta=0^\circ$ $\Phi=0^\circ$	Typ-0 .05	Typ+0. 05	-	1,6	
		y				-		
	R	x				0.305		-
		y				0.330		-
	G	x				0.638		-
		y				0.319		-
	B	x				0.265		-
		y				0.577		-
S	x	0.141	-					
	y	0.091	-					
NTSC Ratio	S	-	70	-	%			

Note: The parameter is slightly changed by temperature, driving voltage and materiel

Note 1: The data are measured after LEDs are turned on for 5 minutes. LCM displays full white. The brightness is the average value of 9 measured spots. Measurement equipment BM-7 (Φ5mm)

Measuring condition:

- Measuring surroundings: Dark room.
- Measuring temperature: Ta=25 °C.
- Adjust operating voltage to get optimum contrast at the center of the display.

Measured value at the center point of LCD panel after more than 5 minutes while backlight

turning on.

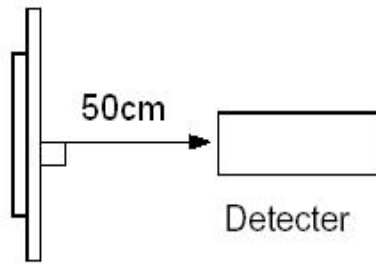

Note 2: The luminance uniformity is calculated by using following formula.

$$\Delta Bp = Bp (\text{Min.}) / Bp (\text{Max.}) \times 100 (\%)$$

$Bp (\text{Max.})$  = Maximum brightness in 9 measured spots

$Bp (\text{Min.})$  = Minimum brightness in 9 measured spots.

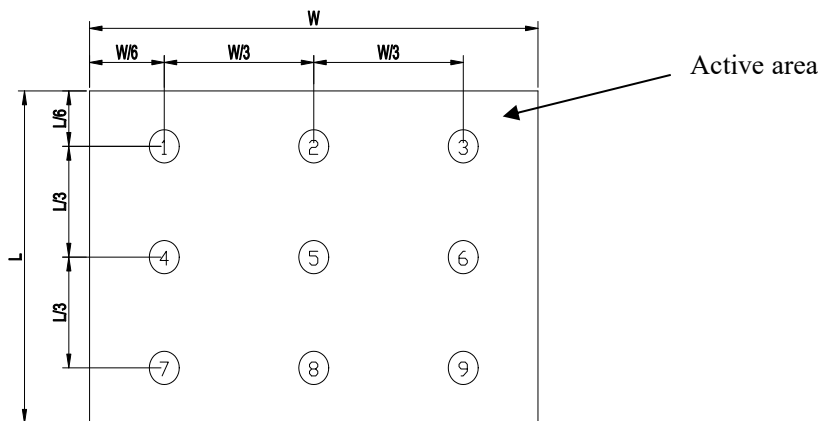

Note 3: The definition of viewing angle:

Refer to the graph below marked by  $\vartheta$  and  $\phi$

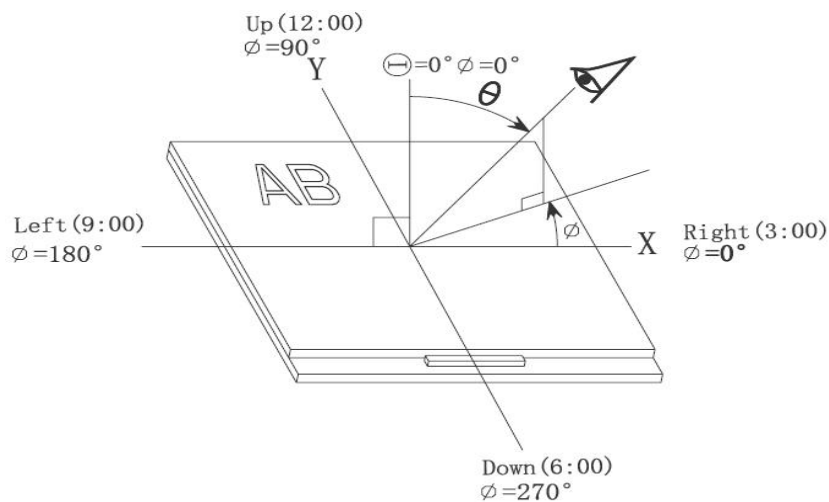

Note 4: Definition of contrast ratio.( Test LCD using DMS501)

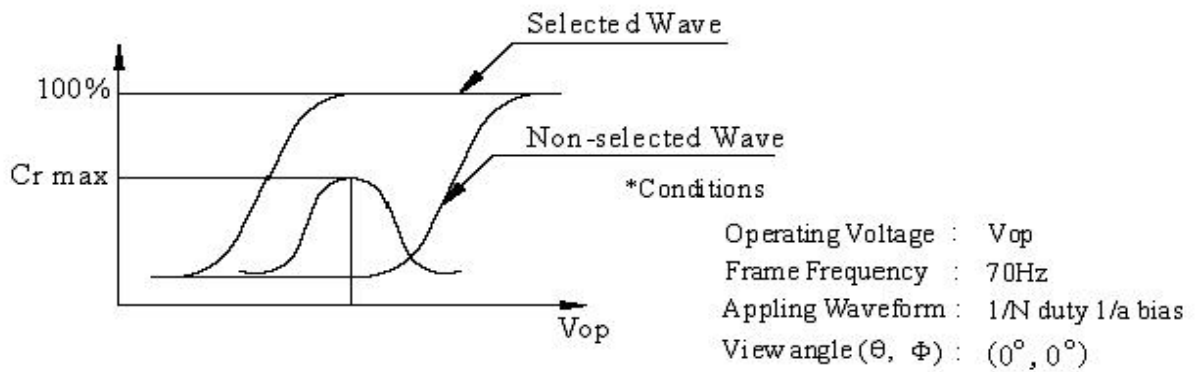

$$\text{Contrast ratio}(Cr) = \frac{\text{Brightness of selected dots}}{\text{Brightness of non-selected dots}}$$

Note 5: Definition of Response time. (Test LCD using DMS501):

The output signals of photo detector are measured when the input signals are changed from "black" to "white"(falling time) and from "white" to "black"(rising time), respectively. The response time is defined as the time interval between the 10% and 90% of amplitudes. Refer to figure as below.

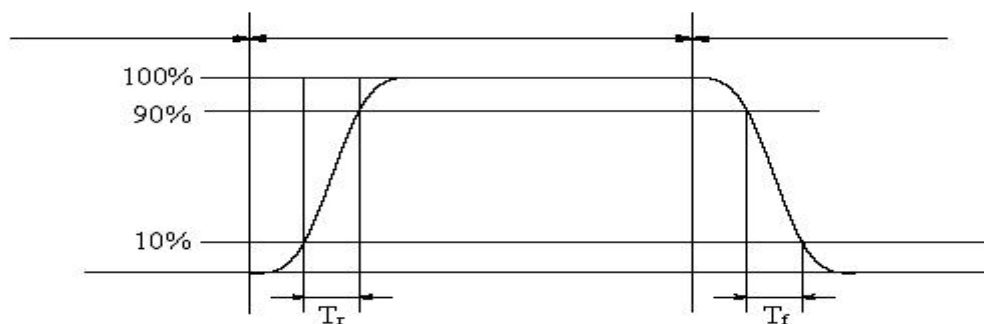

The definition of response time

Note 6: Definition of Color of CIE Coordinate and NTSC Ratio.

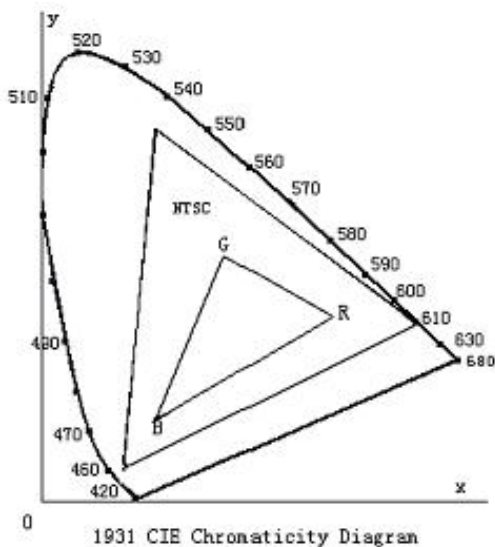

Color gamut:

$$S = \frac{\text{area of RGB triangle}}{\text{area of NTSC triangle}} \times 100\%$$

Note 7: Definition of cross talk.

---

*Cross talk ratio(%)=|pattern A Brightness-pattern B Brightness|/pattern A Brightness\*100*

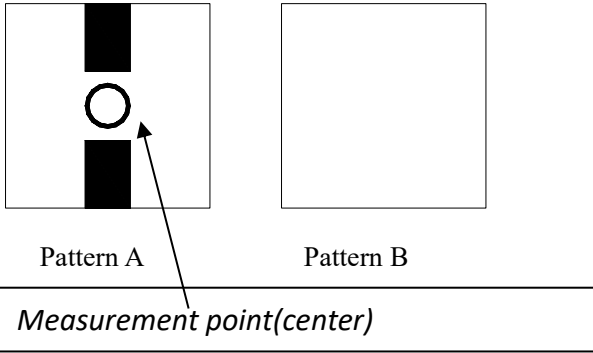

*Electric volume value=3F+/-3Hex*

## 8. Reliability Test Items and Criteria

No	Test Item	Test condition	Criterion
1	High Temperature Storage	80°C±2°C 96H Restore 2H at 25°C Power off	1. After testing, cosmetic and electrical defects should not happen. 2. Total current consumption should not be more than twice of initial value.
2	Low Temperature Storage	-30°C±2°C 96H Restore 2H at 25°C Power off	
3	High Temperature Operation	80°C±2°C 96H Restore 2H at 25°C Power on	
4	Low Temperature Operation	-30°C±2°C 96H Restore 4H at 25°C Power on	
5	High Temperature/Humidity Operation	60°C±2°C 90%RH 96H Power on	
6	Temperature Cycle	<del>-30°C</del> → 80°C 30min 5min 30min after 5 cycle, Restore 2H at 25°C Power off	

Note: Operation: Supply 3.3V for logic system.

The inspection terms after reliability test, as below

ITEM	Inspection
Contrast	CR>50%
IDD	IDD<200%
Brightness	Brightness>60%
Color Tone	Color Tone+/-0,05

## 9. Precautions for Use of LCD Modules

### 9.1 Handling Precautions

9.1.1 *The display panel is made of glass. Do not subject it to a mechanical shock by dropping it from a high place, etc.*

9.1.2 *If the display panel is damaged and the liquid crystal substance inside it leaks out, be sure not to get any in your mouth, if the substance comes into contact with your skin or clothes, promptly wash it off using soap and water.*

9.1.3 *Do not apply excessive force to the display surface or the adjoining areas since this may cause the color tone to vary.*

9.1.4 *The polarizer covering the display surface of the LCD module is soft and easily scratched. Handle this polarizer carefully.*

9.1.5 *If the display surface is contaminated, breathe on the surface and gently wipe it with a soft dry cloth. If still not completely clear, moisten cloth with one of the following solvents:*

— Isopropyl alcohol                      — Ethyl alcohol

*Solvents other than those mentioned above may damage the polarizer. Especially, do not use the following:*

— Water                                      — Ketone                                      — Aromatic solvents

9.1.6 *Do not attempt to disassemble the LCD Module.*

9.1.7 *If the logic circuit power is off, do not apply the input signals.*

9.1.8 *To prevent destruction of the elements by static electricity, be careful to maintain an optimum work environment.*

*a. Be sure to ground the body when handling the LCD Modules.*

*b. Tools required for assembly, such as soldering irons, must be properly ground.*

*c. To reduce the amount of static electricity generated, do not conduct assembly and other work under dry conditions.*

*d. The LCD Module is coated with a film to protect the display surface. Be care when peeling off this protective film since static electricity may be generated.*

## **9.2 Storage precautions**

9.2.1 *When storing the LCD modules, avoid exposure to direct sunlight or to the light of fluorescent lamps.*

9.2.2 *The LCD modules should be stored under the storage temperature range. If the LCD modules will be stored for a long time, the recommend condition is:*

*Temperature :        0 °C ~ 40 °C*

*Relatively humidity: ≤80%*

9.2.3 *The LCD modules should be stored in the room without acid, alkali and harmful gas.*

**9.3 *The LCD modules should be no falling and violent shocking during transportation, and also should avoid excessive press, water, damp and sunshine.***

**END**