

# *IIDWay Technology Co. Ltd*

## **PRODUCT SPECIFICATIONS**

For Customer: \_\_\_\_\_

: APPROVAL FOR SPECIFICATION

Customer Model No. \_\_\_\_\_

: APPROVAL FOR SAMPLE

Module No.:     GZ70139-DIT101WX    

    Date : 2023.6.7    

### **Table of Contents**

No.	Item	Page
1	Cover Sheet(Table of Contents)	P1
2	Revision Record	P2
3	General Specifications	P3
4	Outline Drawing	P4
5	Absolute Maximum Ratings	P5
6	Electrical Specifications	P6-P12
7	Optical Characteristics	P13-P16
8	Reliability Test Items and Criteria	P17
9	Precautions for Use of LCD Modules	P18-P19

### **For Customer's Acceptance:**

Approved By	Comment

PREPARED	CHECKED	APPROVER
YZJ		



# *IIDWay Technology Co. Ltd*

## **3. General Specifications**

*GZ70139-DIT101WX is a TFT-LCD module. It is composed of a TFT-LCD panel, driver IC, FPC, a back light unit. The 10.1" display area contains 1280x800 pixels and can display up to 16.7M colors. This product accords with RoHS environmental criterion.*

Item	Contents	Unit	Note
LCD Type	TFT	-	
Display color	16.7M		
Viewing Direction	ALL	O'Clock	
Operating temperature	-30~+85	°C	
Storage temperature	-30~+85	°C	
Module size	Refer to outline drawing	mm	
Active Area(W×H)	216.96X135.60	mm	
Number of Dots	1280×800	dots	
Driver IC	EK79202	-	
Power Supply Voltage	3.3	V	
Outline Dimensions	Refer to outline drawing	-	
Backlight	7S6P-LEDs (white)	pcs	
Interface	LVDS	-	

# IIDWay Technology Co. Ltd

## 4.Outline.Drawing

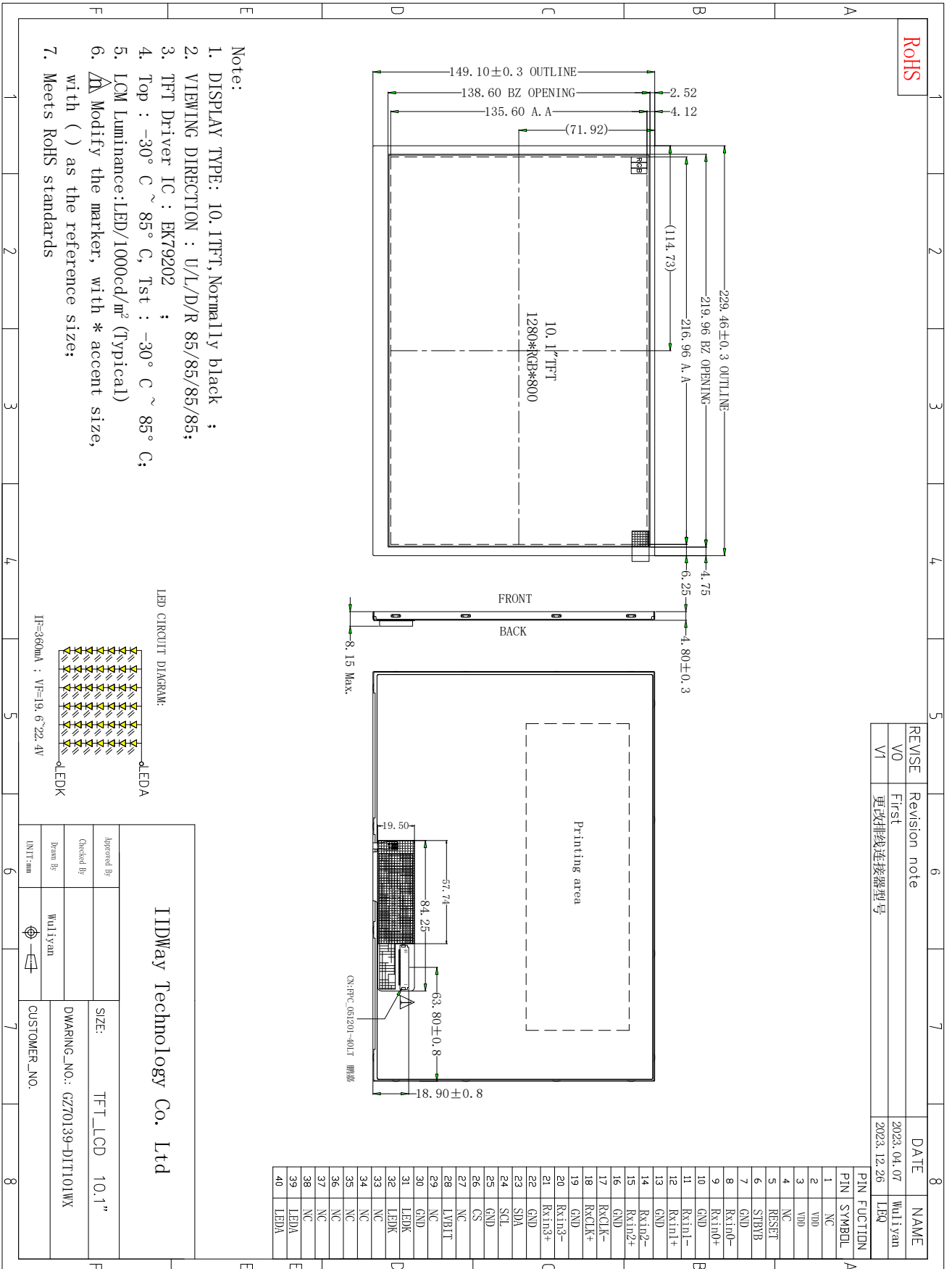

# IIDWay Technology Co. Ltd

## 5. Absolute Maximum Ratings( $T_a=25^\circ\text{C}$ )

### 5.1 Electrical Absolute Maximum Ratings.( $V_{SS}=0\text{V}$ , $T_a=25^\circ\text{C}$ )

Item	Symbol	Min.	Max.	Unit	Note
Power Supply Voltage	$V_{DD}$	2.3	3.6	V	1, 2

Notes:

1. If the module is above these absolute maximum ratings. It may become permanently damaged. Using the module within the following electrical characteristic conditions are also exceeded, the module will malfunction and cause poor reliability.

2.  $V_{DD} > V_{SS}$  must be maintained.

3. Please be sure users are grounded when handing LCD Module.

### 5.2 Environmental Absolute Maximum Ratings.

Item	Storage		Operating	
	MIN.	MAX.	MIN.	MAX.
Ambient Temperature	$-30^\circ\text{C}$	$85^\circ\text{C}$	$-30^\circ\text{C}$	$85^\circ\text{C}$
Humidity	-	-	-	-

1. The response time will become lower when operated at low temperature.

2. Background color changes slightly depending on ambient temperature.

The phenomenon is reversible.

3.  $T_a \leq 40^\circ\text{C}$ : 85%RH MAX.

$T_a > 40^\circ\text{C}$ : Absolute humidity must be lower than the humidity of 85%RH at  $40^\circ\text{C}$ .

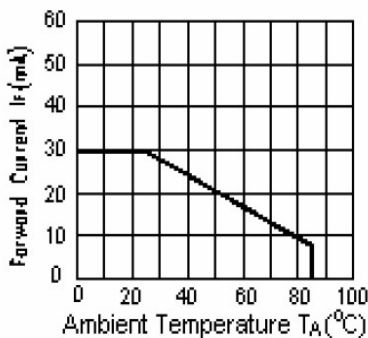

I<sub>LED</sub> VS TEMP

# IIDWay Technology Co. Ltd

## 6. Electrical Specifications and Instruction Code

### 6.1 Electrical characteristics( $V_{SS}=0V, T_a=25^\circ C$ )

Parameter	Symbol	Condition	Min	Typ	Max	Unit	Note
Power supply	VDD	$T_a=25^\circ C$	3.0	3.3	3.6	V	
Input voltage	'H'	$V_{IH}$	$V_{DD}=3.3V$	$0.7V_{DD}$	-	$V_{DD}$	V
	'L'	$V_{IL}$	$V_{DD}=3.3V$	0	-	$0.3V_{DD}$	V

Note: If one of the above items is exceeded its maximum limitation momentarily, the quality of the product may be degraded. Absolute maximum limitation, therefore, specify the values exceeding which the product may be physically damaged. Be sure to use the product within the recommend range.

### 6.2 LED backlight specification( $V_{SS}=0V, T_a=25^\circ C$ )

Item	Symbol	Condition	Min	Typ	Max	Unit	Note
Supply voltage VLED	$V_f$	$I_f=360mA$	19.6	21	22.4	V	
Uniformity	$\Delta B_p$	$I_f=360mA$	70	-	-	%	
LED Life Time	-	-	30000	-	-	hr	1

Note 1: Brightness to be decreased to 50% of the initial value at ambient temperature  $T_A=25^\circ C$

# IIDWay Technology Co. Ltd

## 6.3 Interface signals

### 6.3.1 LCM PIN

Pin No.	Symbol	I/O	Function
1	NC		No Connection
2-3	VCC	P	Power for digital circuit
4	NC		No Connection
5	RESET	I	Global reset pin
6	STBYB	I	Stand mode: SBYB=1,normal operation SBYB=0,timing control,source driver will turn off,all output are high-Z
7	GND	P	Ground
8	Rxin0-	I	-LVDS differential data input
9	Rxin0+	I	+LVDS differential data input
10	GND	P	Ground
11	Rxin1-	I	-LVDS differential data input
12	Rxin1+	I	+LVDS differential data input
13	GND	P	Ground
14	Rxin2-	I	-LVDS differential data input
15	Rxin2+	I	+LVDS differential data input
16	GND	P	Ground
17	RxCLK-	I	-LVDS differential clock input
18	RxCLK+	I	+LVDS differential clock input
19	GND	P	Ground
20	Rxin3-	I	-LVDS differential data input
21	Rxin3+	I	+LVDS differential data input
22	GND	P	Ground
23	SDA	I	Serial communication data input.
24	SCL	I	Serial communication clock input.
25	GND	P	Ground
26	CS	I	Chip select signal
27	NC		No Connection

# IIDWay Technology Co. Ltd

28	LVBIT	I	6-bit / 8-bit input select for LVDS mode. <b>Normally pull high.</b> (only for LVDS, MIPI Mode = Dummy)	
			<b>LVBIT</b>	<b>Function</b>
			H	8-bit (default)
			L	6-bit
29	NC		No Connection	
30	GND	P	Ground	
31-32	LEDK	P	LED back light(Cathode)	
33-38	NC		No Connection	
39-40	LEDA	P	LED back light(Anode)	

# IIDWay Technology Co. Ltd

## 6.4 Power Sequence

Power on :

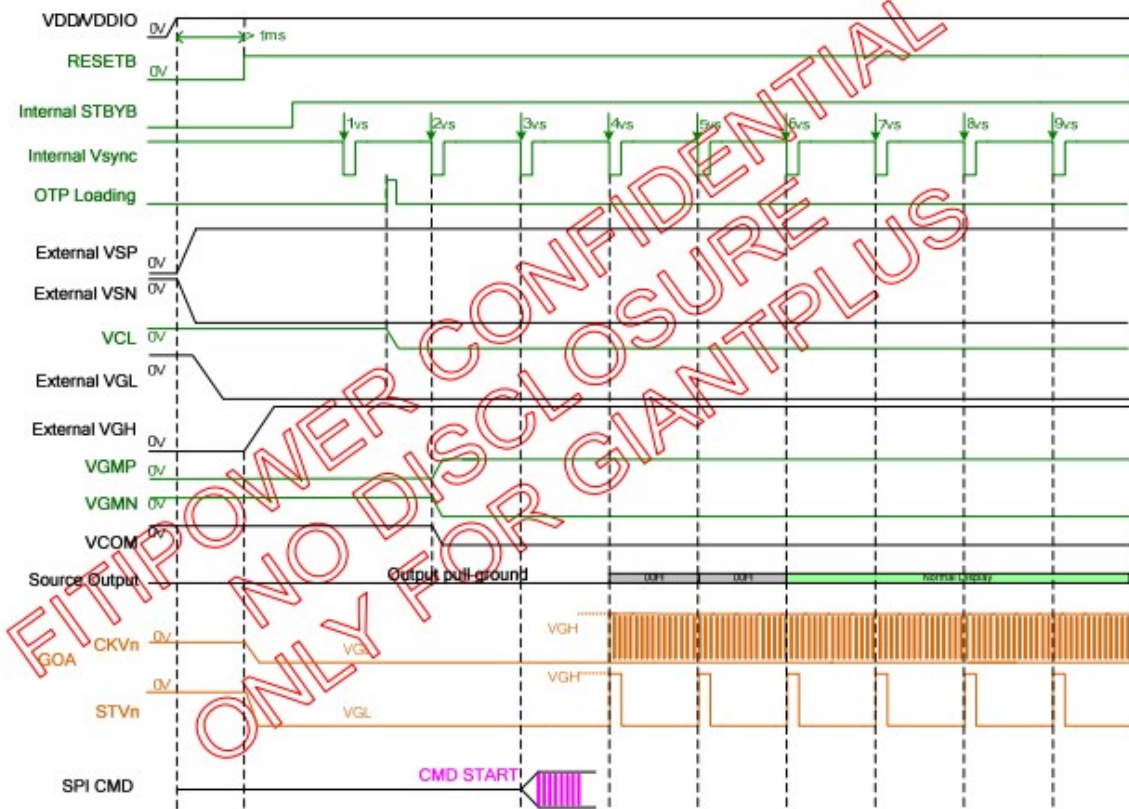

Power off:

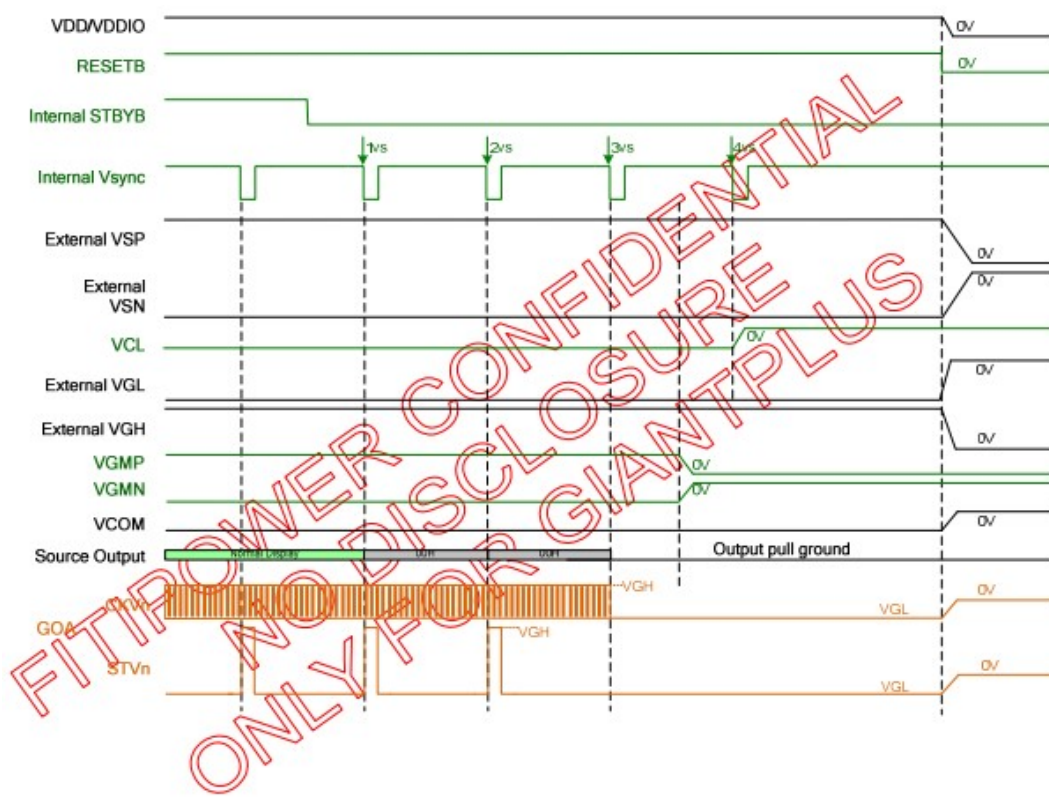

# IIDWay Technology Co. Ltd

## 6.5 Timing Characteristics

### 6.5.1 AC Electrical Characteristics

Parameter	Symbol	Spec.			Unit	Condition
		Min.	Typ.	Max.		
Clock frequency	$R_{xCLK}$	30	-	TBD	MHz	Refer to input timing table for each display resolution
Input data skew margin	$T_{RSKM}$	500	-	-	ps	$ VID  = 200mV$ $R_{xVCM} = 1.2V$ $R_{xCLK} = 81MHz$
Clock high time	$T_{LVCH}$	-	$4/(7 * R_{xCLK})$	-	ns	
Clock low time	$T_{LVCL}$	-	$3/(7 * R_{xCLK})$	-	ns	
PLL wake-up time	$T_{enPLL}$	-	-	150	us	

Table 13.1: LVDS mode AC electrical characteristics

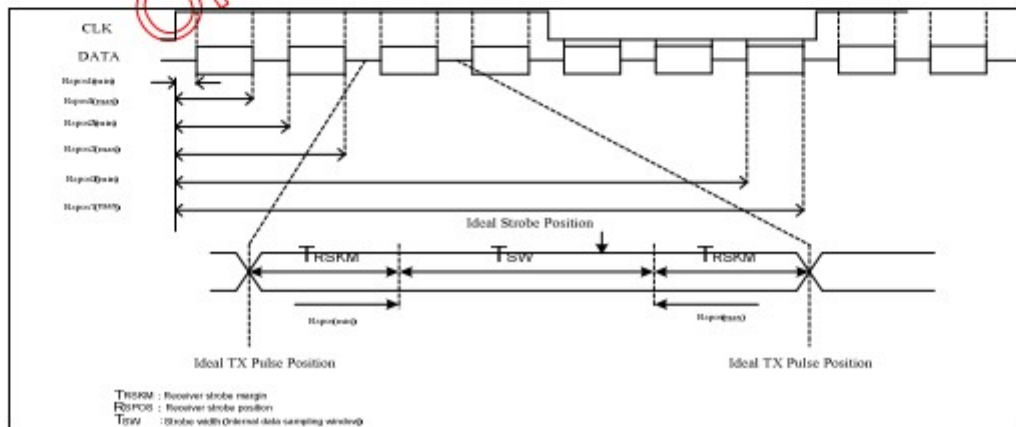
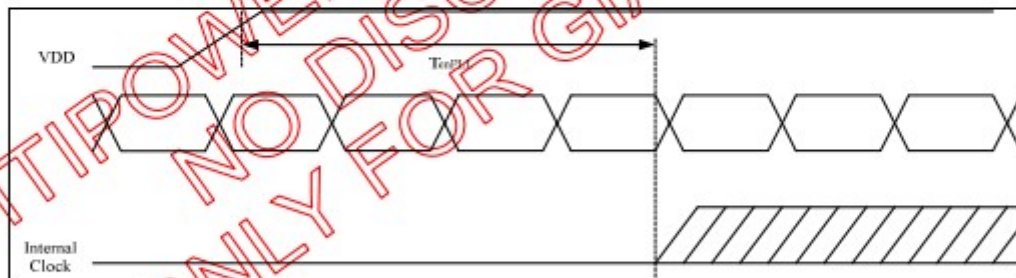

# IIDWay Technology Co. Ltd

## 6.6.2 Timing Diagram

### 6.6.2.1 Data Input Format

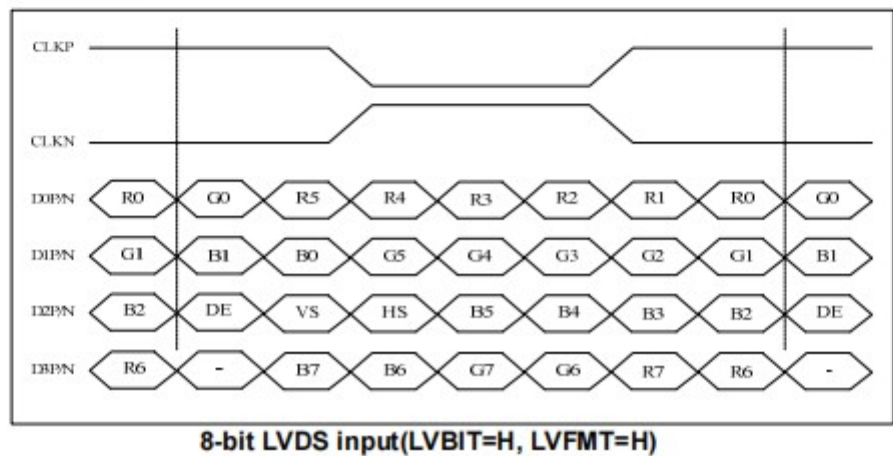
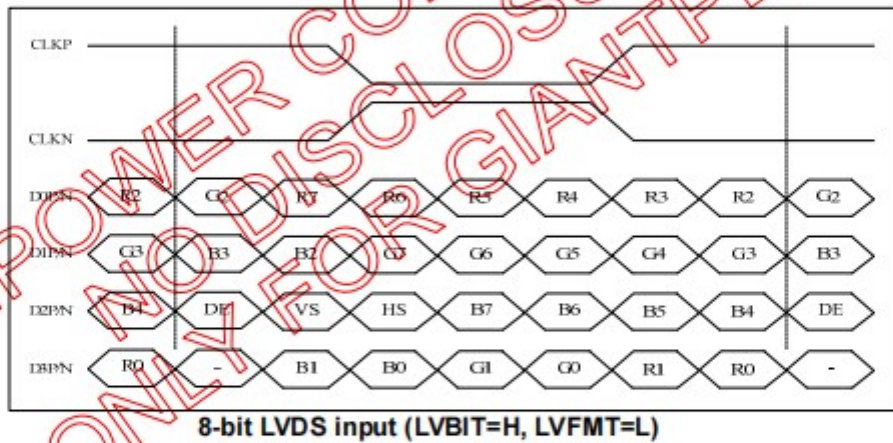
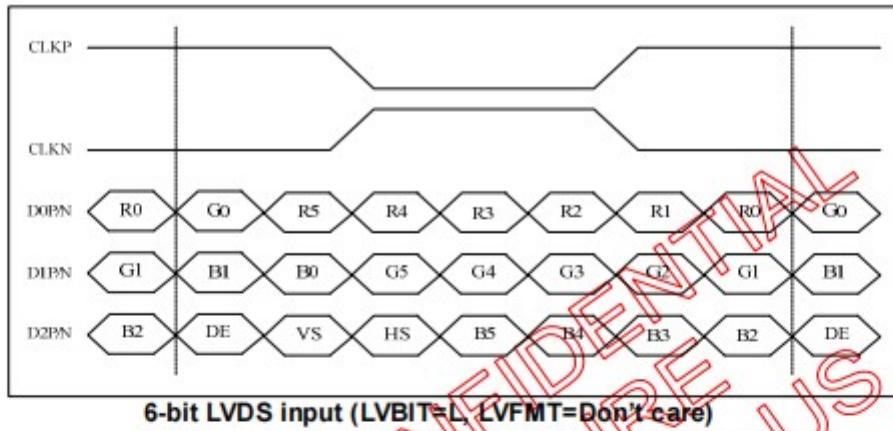

# IIDWay Technology Co. Ltd

## 6.6.2.2 Data Input Timing Table

Parameter	Symbol	Value			Unit
		Min.	Typ.	Max.	
DCLK frequency @Frame rate=60Hz (LVDS)	F <sub>DCLK</sub>	66.3	72.4	78.9	MHz
HSYNC period time	T <sub>H</sub>	1380	1440	1500	DCLK
Horizontal display area	T <sub>HD</sub>	1280			DCLK
HSYNC pulse width	T <sub>HPW</sub>	Min.	1		
		Typ.	-		
		Max.	40		
HSYNC back porch(with pulse width)	T <sub>HBP</sub>	88	88	88	DCLK
HSYNC front porch	T <sub>HFP</sub>	12	72	132	DCLK
VSYNC period time	T <sub>V</sub>	824	838	872	H
Vertical display area	T <sub>VD</sub>	800			H
VSYNC pulse width	T <sub>VPW</sub>	Min.	1		H
		Typ.	-		
		Max.	20		
VSYNC back porch(with pulse width)	T <sub>VBP</sub>	23	23	23	H
VSYNC front porch	T <sub>VFP</sub>	1	15	49	H

# IIDWay Technology Co. Ltd

## 7. Optical Characteristics

Item	Symbol	Condition	Min.	Typ.	Max.	Unit	Note
Brightness	Bp	$\theta=0^\circ$	900	1000	-	Cd/m <sup>2</sup>	1
Uniformity	$\Delta Bp$	$\Phi=0^\circ$	70	-	-	%	1,2
Viewing Angle	3:00	Cr $\geq$ 10	70	80	-	Deg	3
	6:00		70	80	-		
	9:00		70	80	-		
	12:00		70	80	-		
Contrast Ratio	Cr	$\theta=0^\circ$ $\Phi=0^\circ$	800	1000	-	-	4
Response Time	T <sub>r</sub>		-	10	15	ms	5
	T <sub>f</sub>		-	15	20	ms	
Color of CIE Coordinate	W	x	$\theta=0^\circ$ $\Phi=0^\circ$	Typ-0 .05	Typ+0. 05	-	1,6
		y				-	
	R	x				-	
		y				-	
	G	x				-	
		y				-	
	B	x				-	
		y				-	
NTSC Ratio	S		45	50	-	%	

Note : The parameter is slightly changed by temperature, driving voltage and materiel

Note 1: The data are measured after LEDs are turned on for 5 minutes. LCM displays full white. The brightness is the average value of 9 measured spots. Measurement equipment BM-7 ( $\Phi$ 5mm)

Measuring condition:

- Measuring surroundings: Dark room.
- Measuring temperature: Ta=25 °C.
- Adjust operating voltage to get optimum contrast at the center of the display.

# IIDWay Technology Co. Ltd

Measured value at the center point of LCD panel after more than 5 minutes while backlight turning on.

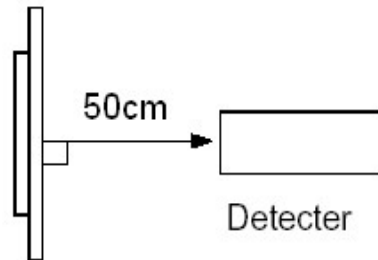

Note 2: The luminance uniformity is calculated by using following formula.

$$\Delta Bp = Bp (\text{Min.}) / Bp (\text{Max.}) \times 100 (\%)$$

$Bp (\text{Max.})$  = Maximum brightness in 9 measured spots

$Bp (\text{Min.})$  = Minimum brightness in 9 measured spots.

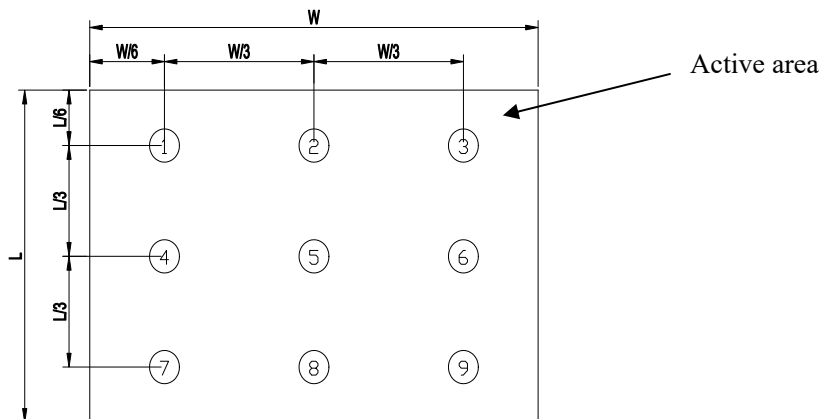

Note 3: The definition of viewing angle:

Refer to the graph below marked by  $\vartheta$  and  $\phi$

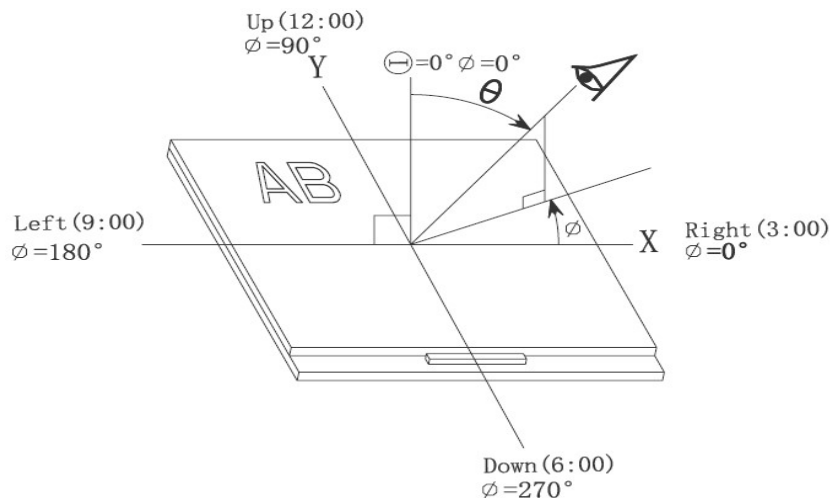

# IIDWay Technology Co. Ltd

Note4: Definition of Contrast Ratio (CR) :

measured at the center point of panel

$$CR = \frac{\text{Luminance with all pixels white}}{\text{Luminance with all pixels black}}$$

Note 5: Definition of Response time:

The output signals of photo detector are measured when the input signals are changed from "black" to "white"(falling time) and from "white" to "black"(rising time), respectively. The response time is defined as the time interval between the 10% and 90% of amplitudes. Refer to figure as below.

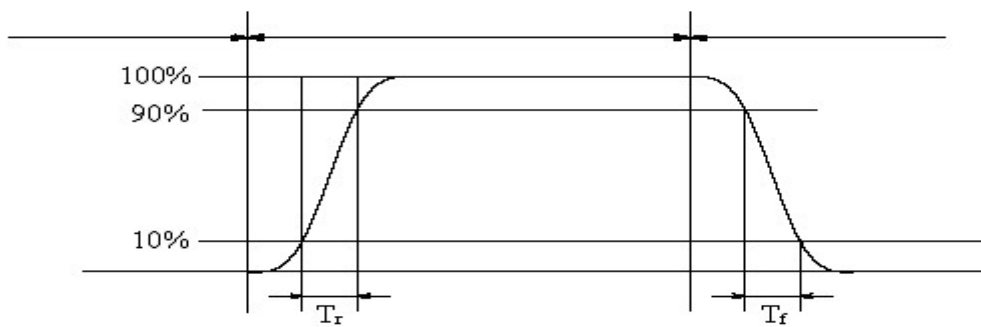

The definition of response time

Note 6: Definition of Color of CIE Coordinate and NTSC Ratio.

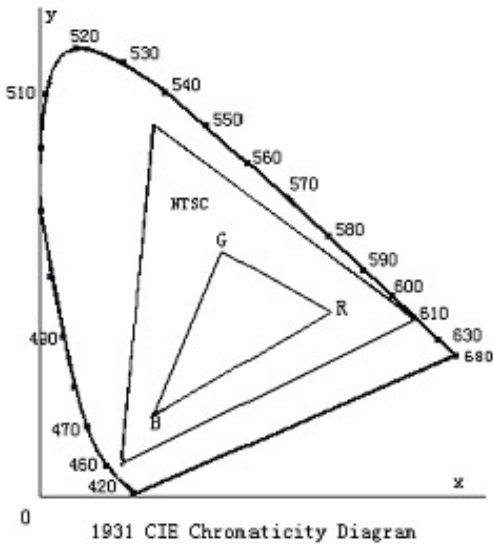

Color gamut:

$$S = \frac{\text{area of RGB triangle}}{\text{area of NTSC triangle}} \times 100\%$$

Note 7: Definition of cross talk.

Cross talk ratio(%) =  $\frac{|\text{pattern A Brightness} - \text{pattern B Brightness}|}{\text{pattern A Brightness}} \times 100$

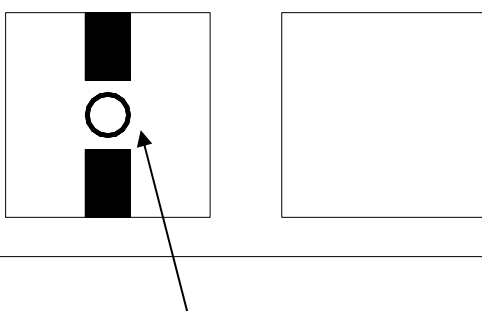

# *IIDWay Technology Co. Ltd*

---

Pattern A

Pattern B

*Measurement point(center)*

*Electric volume value=3F+/-3Hex*

# *IIDWay Technology Co. Ltd*

## 8. Reliability Test Items and Criteria

No	Test Item	Test condition	Criterion
1	High Temperature Storage	85°C±2°C 96H Restore 2H at 25°C Power off	1. After testing, cosmetic and electrical defects should not happen. 2. Total current consumption should not be more than twice of initial value.
2	Low Temperature Storage	-30°C±2°C 96H Restore 2H at 25°C Power off	
3	High Temperature Operation	85°C±2°C 96H Restore 2H at 25°C Power on	
4	Low Temperature Operation	-30°C±2°C 96H Restore 4H at 25°C Power on	
5	High Temperature/Humidity Operation	60°C±2°C 90%RH 96H Power on	
6	Temperature Cycle	<del>-30°C</del> → 80°C 30min 5min 30min after 5 cycle, Restore 2H at 25°C Power off	

Note: Operation: Supply 3.3V for logic system.

The inspection terms after reliability test, as below

ITEM	Inspection
Contrast	CR>50%
IDD	IDD<200%
Brightness	Brightness>60%
Color Tone	Color Tone+/-0,05

## **9. Precautions for Use of LCD Modules**

### **9.1 Handling Precautions**

9.1.1 *The display panel is made of glass. Do not subject it to a mechanical shock by dropping it from a high place, etc.*

9.1.2 *If the display panel is damaged and the liquid crystal substance inside it leaks out, be sure not to get any in your mouth, if the substance comes into contact with your skin or clothes, promptly wash it off using soap and water.*

9.1.3 *Do not apply excessive force to the display surface or the adjoining areas since this may cause the color tone to vary.*

9.1.4 *The polarizer covering the display surface of the LCD module is soft and easily scratched. Handle this polarizer carefully.*

9.1.5 *If the display surface is contaminated, breathe on the surface and gently wipe it with a soft dry cloth. If still not completely clear, moisten cloth with one of the following solvents:*

— Isopropyl alcohol            — Ethyl alcohol

*Solvents other than those mentioned above may damage the polarizer. Especially, do not use the following:*

— Water                            — Ketone                            — Aromatic solvents

9.1.6 *Do not attempt to disassemble the LCD Module.*

9.1.7 *If the logic circuit power is off, do not apply the input signals.*

9.1.8 *To prevent destruction of the elements by static electricity, be careful to maintain an optimum work environment.*

*a. Be sure to ground the body when handling the LCD Modules.*

*b. Tools required for assembly, such as soldering irons, must be properly ground.*

*c. To reduce the amount of static electricity generated, do not conduct assembly and other work under dry conditions.*

*d. The LCD Module is coated with a film to protect the display surface. Be care when peeling off this protective film since static electricity may be generated.*

## **9.2 Storage precautions**

9.2.1 *When storing the LCD modules, avoid exposure to direct sunlight or to the light of fluorescent lamps.*

9.2.2 *The LCD modules should be stored under the storage temperature range. If the LCD modules will be stored for a long time, the recommend condition is:*

*Temperature :           0°C ~ 40°C*

*Relatively humidity: ≤80%*

9.2.3 *The LCD modules should be stored in the room without acid, alkali and harmful gas.*

**9.3 *The LCD modules should be no falling and violent shocking during transportation, and also should avoid excessive press, water, damp and sunshine.***

**END**