

IIDWay Technology Co. Ltd

PRODUCT SPECIFICATIONS

For Customer: _____

: APPROVAL FOR SPECIFICATION

Customer Model No. _____

: APPROVAL FOR SAMPLE

Module No.: GZ70118-DIT035HV

Date : 2024-03-28

Table of Contents

No.	Item	Page
1	Cover Sheet(Table of Contents)	P1
2	Revision Record	P2
3	General Specifications	P3
4	Outline Drawing	P4
5	Absolute Maximum Ratings	P5
6	Electrical Specifications	P6-P16
7	Optical Characteristics	P17-P20
8	Reliability Test Items and Criteria	P21
9	Precautions for Use of LCD Modules	P22-P23

For Customer's Acceptance:

Approved By	Comment

PREPARED	CHECKED	APPROVER
ZKJ		

IIDWay Technology Co. Ltd

3. General Specifications

GZ70118-DIT035HV is a TFT-LCD module. It is composed of a TFT-LCD panel, driver IC, FPC, a back light unit. The 3.5" display area contains 320X480 pixels and can display up to 16.7M colors. This product accords with RoHS environmental criterion.

Item	Contents	Unit	Note
LCD Type	TFT	-	
Display color	16.7M		
Viewing Direction	ALL	O'Clock	
Operating temperature	-20~+70	°C	
Storage temperature	-30~+80	°C	
Module size	Refer to outline drawing	mm	
Active Area(W×H)	48.96X73.44	mm	
Number of Dots	320X480	dots	
Driver IC	ST7796U	-	
Power Supply Voltage	3.3	V	
Outline Dimensions	Refer to outline drawing	-	
Backlight	1X6-LEDs	pcs	
Interface	RGB&SPI&MCU	-	

IIDWay Technology Co. Ltd

5. Absolute Maximum Ratings($T_a=25\text{ }^\circ\text{C}$)

5.1 Electrical Absolute Maximum Ratings.($V_{SS}=0V$, $T_a=25\text{ }^\circ\text{C}$)

Item	Symbol	Min.	Max.	Unit	Note
Power Supply Voltage	VCI	-0.3	4.6	V	1, 2
Power Supply Voltage	IOVCC	-0.3	4.6	V	

Notes:

1. If the module is above these absolute maximum ratings. It may become permanently damaged. Using the module within the following electrical characteristic conditions are also exceeded, the module will malfunction and cause poor reliability.
2. $V_{DD} > V_{SS}$ must be maintained.
3. Please be sure users are grounded when handing LCD Module.

5.2 Environmental Absolute Maximum Ratings.

Item	Storage		Operating		Note
	MIN.	MAX.	MIN.	MAX.	
Ambient Temperature	-30 $^\circ\text{C}$	80 $^\circ\text{C}$	-20 $^\circ\text{C}$	70 $^\circ\text{C}$	
Humidity	-	-	-	-	

1. The response time will become lower when operated at low temperature.
2. Background color changes slightly depending on ambient temperature.
The phenomenon is reversible.
3. $T_a \leq 40\text{ }^\circ\text{C}$: 85%RH MAX.

$T_a > 40\text{ }^\circ\text{C}$: Absolute humidity must be lower than the humidity of 85%RH at 40 $^\circ\text{C}$.

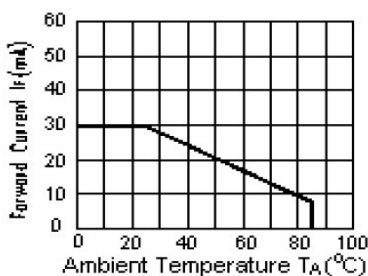

ILED VS TEMP

IIDWay Technology Co. Ltd

6. Electrical Specifications and Instruction Code

6.1 Electrical characteristics($V_{SS}=0V$, $T_a=25^\circ C$)

Parameter	Symbol	Condition	Min	Typ	Max	Unit	Note	
Power Supply Voltage	V_{CI}	$T_a=25^\circ C$	2.6	2.8	3.3	V		
	I_{VCI}		-	19.51	-	mA		
	$IOVCC$		1.65	1.8	3.3	V		
	I_{IOVCC}		-	23.5	-	μA		
Input voltage	'H'	V_{IH}	$V_{CI}=3.3V$	$0.7V_{CI}$	-	V_{CI}	V	
	'L'	V_{IL}	$V_{CI}=3.3V$	0	-	$0.3V_{CI}$	V	

Note: If one of the above items is exceeded its maximum limitation momentarily, the quality of the product may be degraded. Absolute maximum limitation, therefore, specify the values exceeding which the product may be physically damaged. Be sure to use the product within the recommend range.

6.2 LED backlight specification($V_{SS}=0V$, $T_a=25^\circ C$)

Item	Symbol	Condition	Min	Typ	Max	Unit	Note
Supply voltage VLED	V_f	$I_f=120mA$	-	3.0	-	V	
Uniformity	ΔB_p	$I_f=120mA$	80	-	-	%	
LED Life Time	Time	$I_f=120mA$	20K	-	-	hr	1

Note 1: Brightness to be decreased to 50% of the initial value at ambient temperature $T_A=25^\circ C$

IIDWay Technology Co. Ltd

6.3 Interface signals

6.3.1 LCM PIN

Pin No.	Symbol	I/O	Function					
1	GND	P	Ground.					
2-3	IOVCC	P	Power Supply for IO.					
4-5	VCI	P	Power supply.					
6	IM0	I	<table border="1"> <tr> <td>IM2</td> <td>IM1</td> <td>IM0</td> <td>MPU Interface Mode</td> <td>Data pin</td> </tr> </table>	IM2	IM1	IM0	MPU Interface Mode	Data pin
IM2	IM1	IM0	MPU Interface Mode	Data pin				
7	IM1	I	<table border="1"> <tr> <td>1</td> <td>0</td> <td>1</td> <td>3SPI</td> <td>SDA, SDO</td> </tr> </table>	1	0	1	3SPI	SDA, SDO
1	0	1	3SPI	SDA, SDO				
8	IM2	I	<table border="1"> <tr> <td>1</td> <td>1</td> <td>1</td> <td>4Line SPI</td> <td>SDA, SDO</td> </tr> </table>	1	1	1	4Line SPI	SDA, SDO
1	1	1	4Line SPI	SDA, SDO				
9	RESX	I	Global reset signal input pin.					
10	VSYNC	I	Vertical sync signal.					
11	HSYNC	I	Horizontal sync signal.					
12	PCLK	I	Dot clock signal for RGB interface operation.					
13	DE	I	Data enable signal for RGB interface operation.					
14-31	DB17-DB0	I	Data input.					
32	GND	P	Ground.					
33	DOUT	O	SPI interface output pin.					
34	DIN-SDA	I	Serial Input.					
35	RD	I	Read enable in 8080 MCU parallel interface.					
36	WR/SCL	I	Write enable in MCU parallel interface/In SPI mode, this pin is used as SCL.					
37	DCX	I	Display data/command selection (RS) pin					
38	CS	I	Chip select input pin.					
39	XR(NC)	O	RTP pin ,not use please NC.					
40	YD(NC)	O						
41	XL(NC)	O						
42	YU(NC)	O						
43	LEDA	P	LED anode.					
44-49	LEDK	P	LED cathode.					
50	GND	P	Ground.					

IIDWay Technology Co. Ltd

6.4 AC Characteristics

4-SPI Serial Data Transfer Interface Characteristics

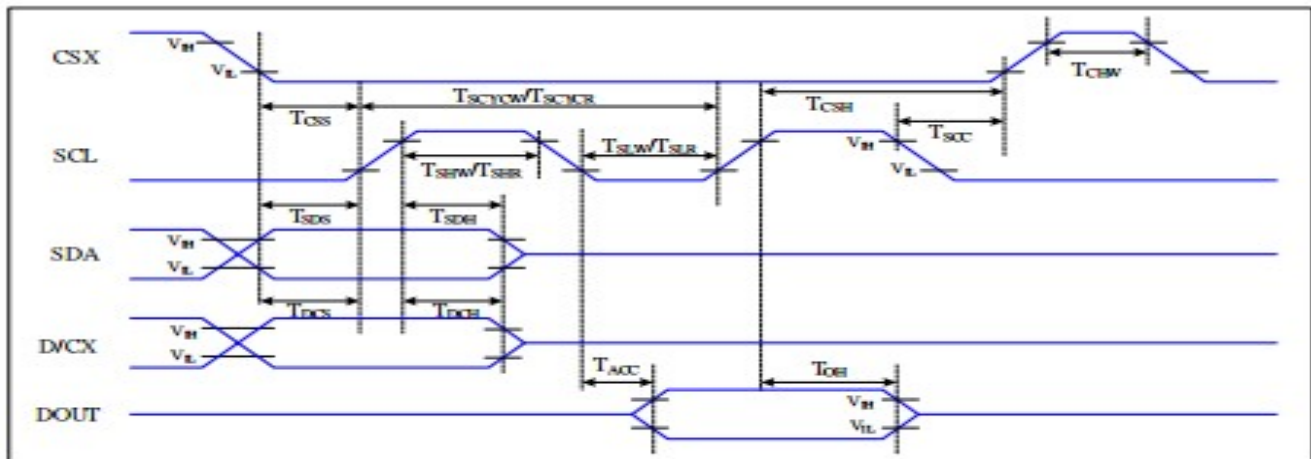

4-SPI Interface Timing Characteristics

Signal	Symbol	Parameter	MIN	MAX	Unit	Description
CSX	T_{CSS}	Chip select setup time (write)	15		ns	
	T_{CSH}	Chip select hold time (write)	15		ns	
	T_{CSS}	Chip select setup time (read)	60		ns	
	T_{SCH}	Chip select hold time (read)	65		ns	
	T_{CHW}	Chip select "H" pulse width	40		ns	
SCL	T_{SCYW}	Serial clock cycle (Write)	66		ns	-write command & data ram
	T_{SHW}	SCL "H" pulse width (Write)	15		ns	
	T_{SLW}	SCL "L" pulse width (Write)	15		ns	
	T_{SCYR}	Serial clock cycle (Read)	150		ns	-read command & data ram
	T_{SHR}	SCL "H" pulse width (Read)	60		ns	
	T_{SLR}	SCL "L" pulse width (Read)	60		ns	
D/CX	T_{DCS}	D/CX setup time	10		ns	
	T_{DCH}	D/CX hold time	10		ns	
SDA (DIN)	T_{SDS}	Data setup time	10		ns	
	T_{SDH}	Data hold time	10		ns	
DOUT	T_{ACC}	Access time	10	50	ns	For maximum CL=30pF
	T_{CH}	Output disable time	15	50	ns	For minimum CL=8pF

3-SPI Serial Data Transfer Interface Characteristics

IIDWay Technology Co. Ltd

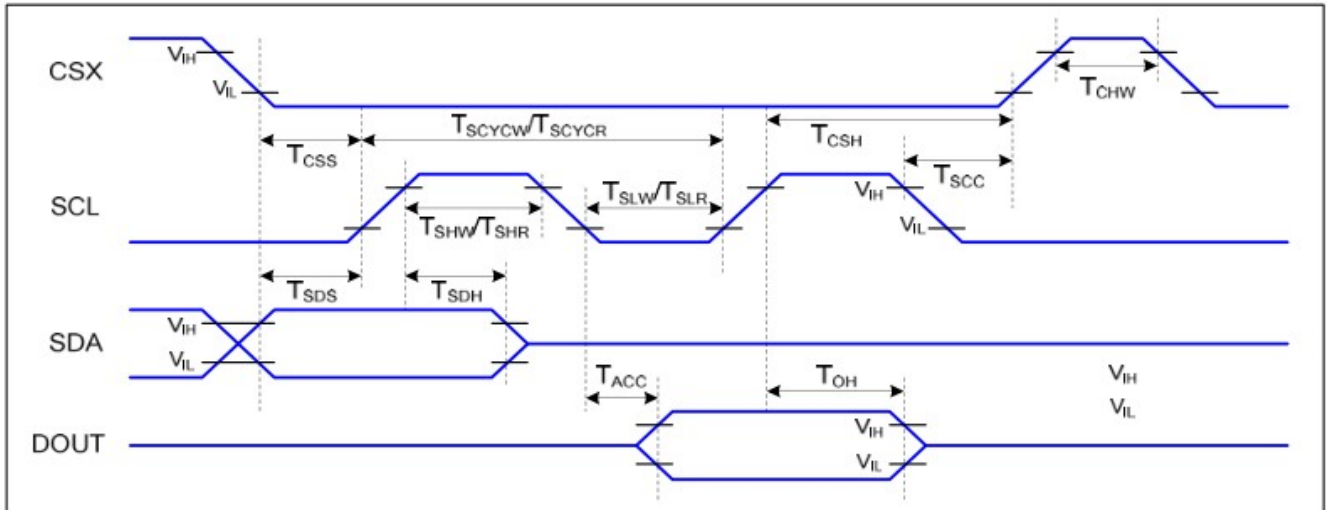

3-SPI Interface Timing Characteristics

Signal	Symbol	Parameter	Min	Max	Unit	Description
CSX	T_{CSS}	Chip select setup time (write)	15		ns	
	T_{CSH}	Chip select hold time (write)	15		ns	
	T_{CSS}	Chip select setup time (read)	60		ns	
	T_{SCC}	Chip select hold time (read)	65		ns	
	T_{CHW}	Chip select "H" pulse width	40		ns	
SCL	T_{SCYCW}	Serial clock cycle (Write)	66		ns	
	T_{SHW}	SCL "H" pulse width (Write)	15		ns	
	T_{SLW}	SCL "L" pulse width (Write)	15		ns	
	T_{SCYCR}	Serial clock cycle (Read)	150		ns	
	T_{SHR}	SCL "H" pulse width (Read)	60		ns	
	T_{SLR}	SCL "L" pulse width (Read)	60		ns	
SDA (DIN)	T_{SDS}	Data setup time	10		ns	
	T_{SDH}	Data hold time	10		ns	
DOUT	T_{ACC}	Access time	10	50	ns	For maximum $CL=30pF$
	T_{OH}	Output disable time	15	50	ns	For minimum $CL=8pF$

3-SPI Interface Characteristics

RGB Interface Timing Characteristics

IIDWay Technology Co. Ltd

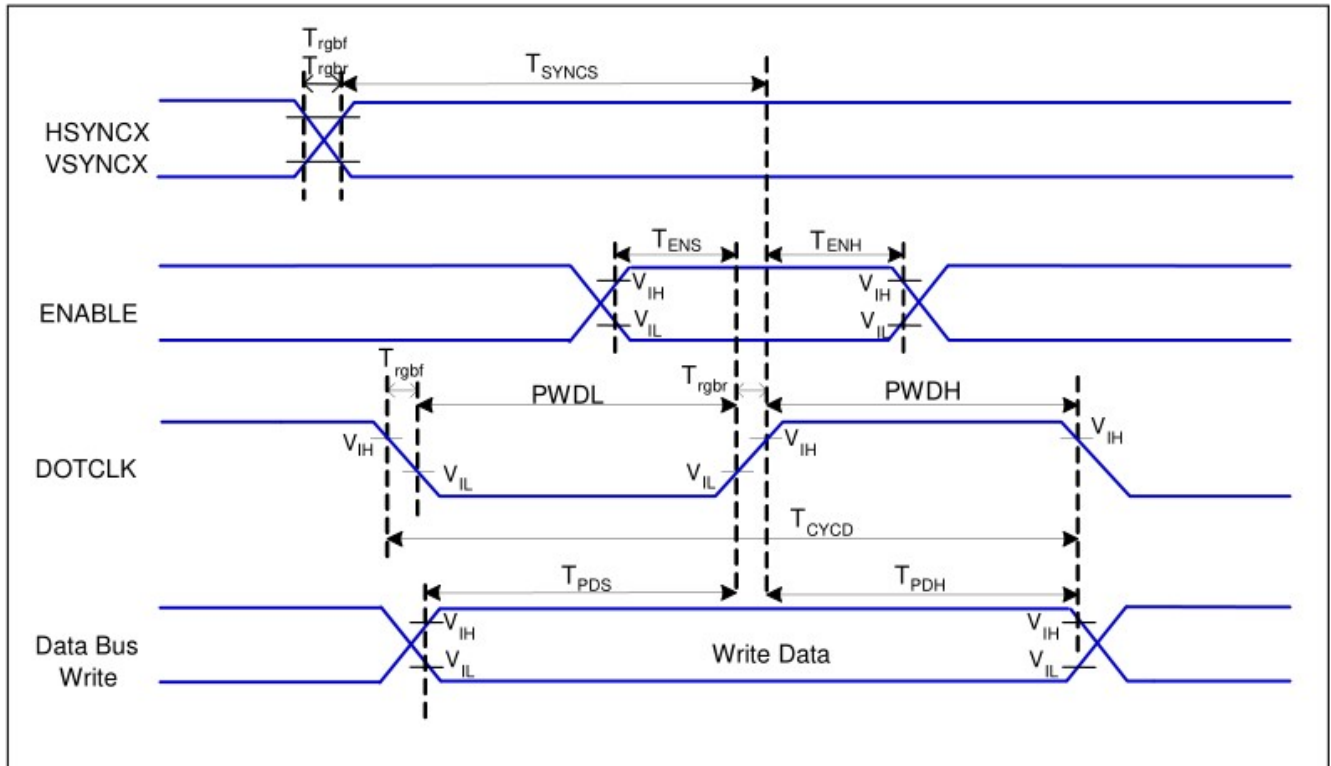

Signal	Symbol	Parameter	MIN	MAX	Unit	Description
HSYNC, VSYNC	T_{SYNCX}	VSNC, HSYNC Setup Time	15	-	ns	
ENABLE	T_{ENS}	Enable Setup Time	15	-	ns	
	T_{ENH}	Enable Hold Time	15	-	ns	
DOTCLK	PVDH	DOTCLK High-level Pulse Width	30	-	ns	
	PVDL	DOTCLK Low-level Pulse Width	30	-	ns	
	T_{CYCD}	DOTCLK Cycle Time	66	-	ns	
	$T_{\text{rghr}}, T_{\text{rgbf}}$	DOTCLK Rise/Fall time	-	15	ns	
DB	T_{PDS}	PD Data Setup Time	15	-	ns	
	T_{PDH}	PD Data Hold Time	15	-	ns	

RGB Interface Timing Characteristics

6.5 RGB Interface

6.5.1 RGB Color Format

IIDWay Technology Co. Ltd

The LCM supports two kinds of RGB interface, DE mode and HV mode, and 16bit/18bit data format. When DE mode is selected and the VSYNC, HSYNC, DOTCLK, DE, D[17:0] pins can be used; when HV mode is selected and the VSYNC, HSYNC, DOTCLK, D[17:0] pins can be used. When using RGB interface, only serial interface can be selected.

Write data for 16-bit/pixel (RGB 5-6-5-bit input), 65K-Colors

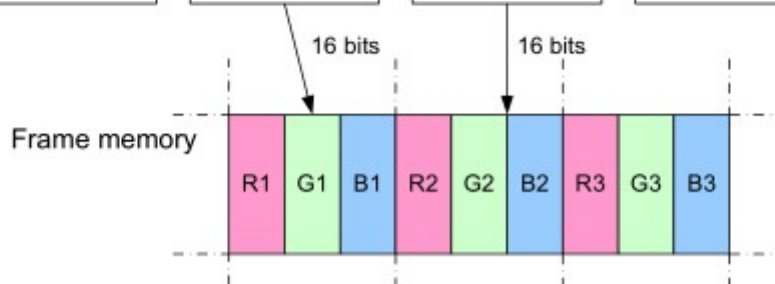

IIDWay Technology Co. Ltd

Write data for 18-bit/pixel (RGB 6-6-6-bit input), 262K-Colors

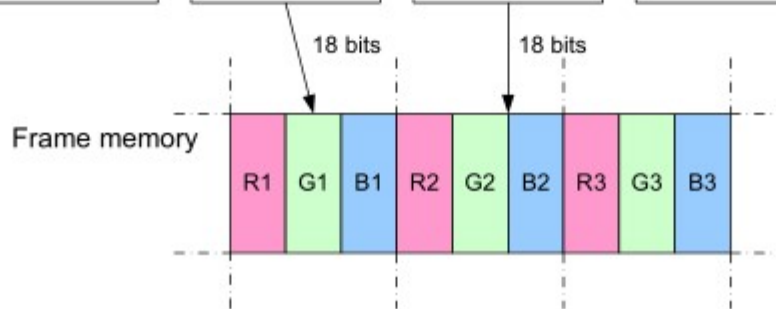
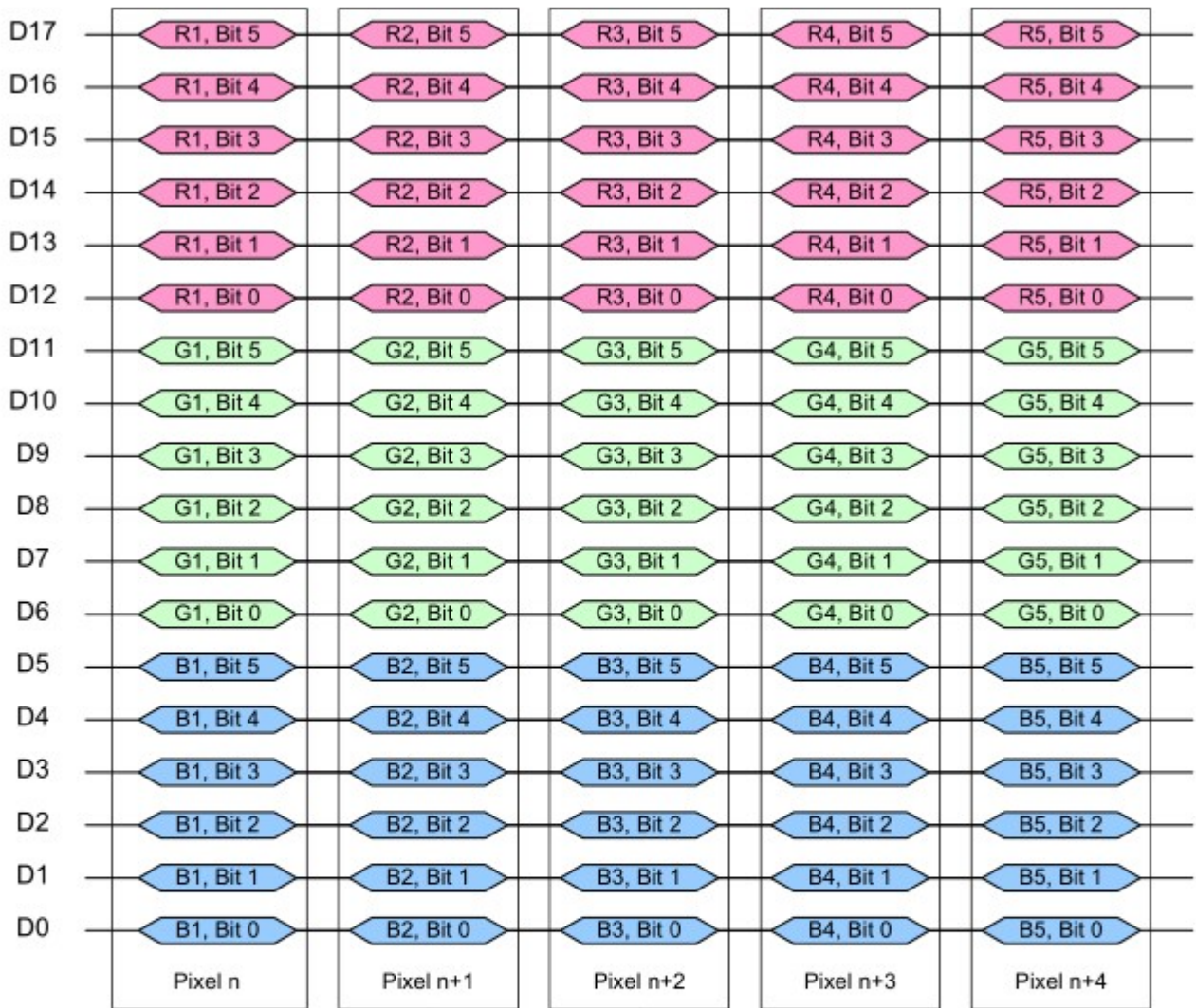

IIDWay Technology Co. Ltd

6.5.2 RGB Interface Definition

The display operation via the RGB interface is synchronized with the VSYNC, HSYNC, and DOTCLK signals. The data can be written only within the specified area with low power consumption by using window address function. The back porch and front porch are used to set the RGB interface timing.

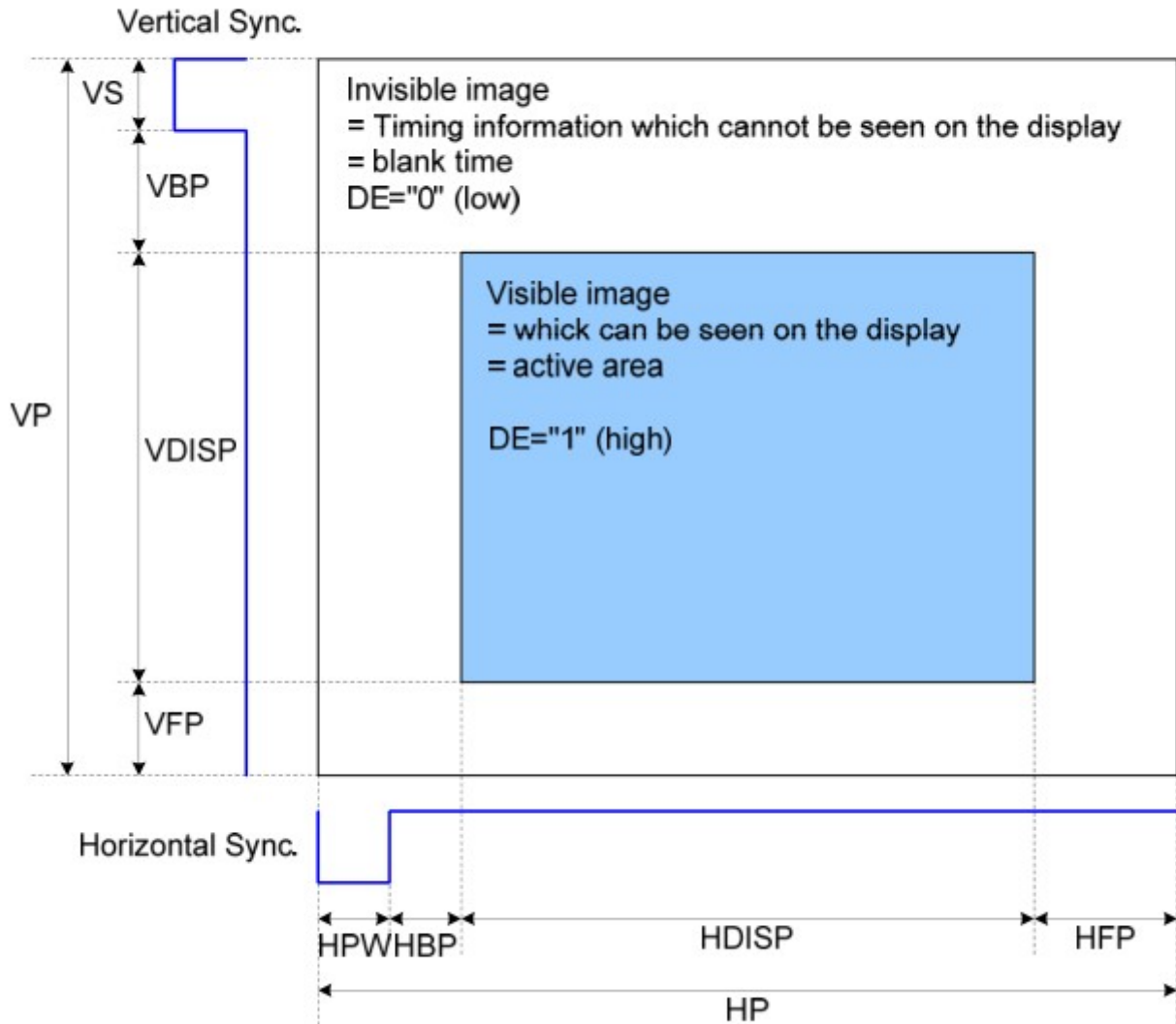

DRAM Access Area by RGB Interface

Please refer to the following table for the setting limitation of RGB interface signals.

Parameter	Symbol	Min.	Typ.	Max.	Unit
Horizontal Sync. Width	hpw	2	-	hpw + hbp = 75	Clock
Horizontal Sync. Back Porch	hbp	4	-		Clock
Horizontal Sync. Front Porch	hfp	2	38	-	Clock
Vertical Sync. Width	vs	2	4	-	Line
Vertical Sync. Back Porch	vbp	2	4		Line
Vertical Sync. Front Porch	vfp	2	8		Line

IIDWay Technology Co. Ltd

6.5.3 RGB Interface Timing

The timing chart of RGB interface DE mode is shown as follows.

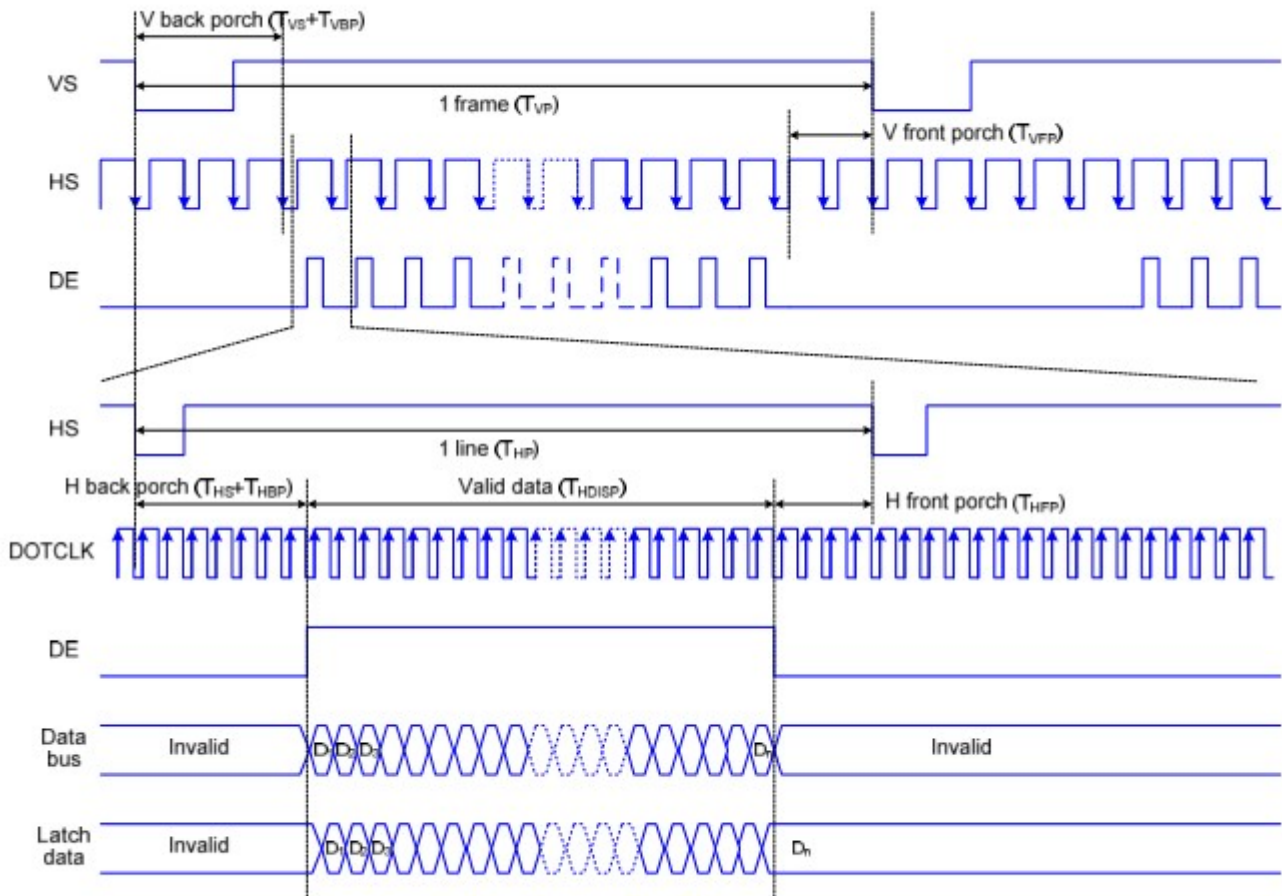

Note: The setting of front porch and back porch in host must match that in IC as this mode.

Timing Chart of Signals in RGB Interface DE Mode

IIDWay Technology Co. Ltd

The timing chart of RGB interface HV mode is shown as follows.

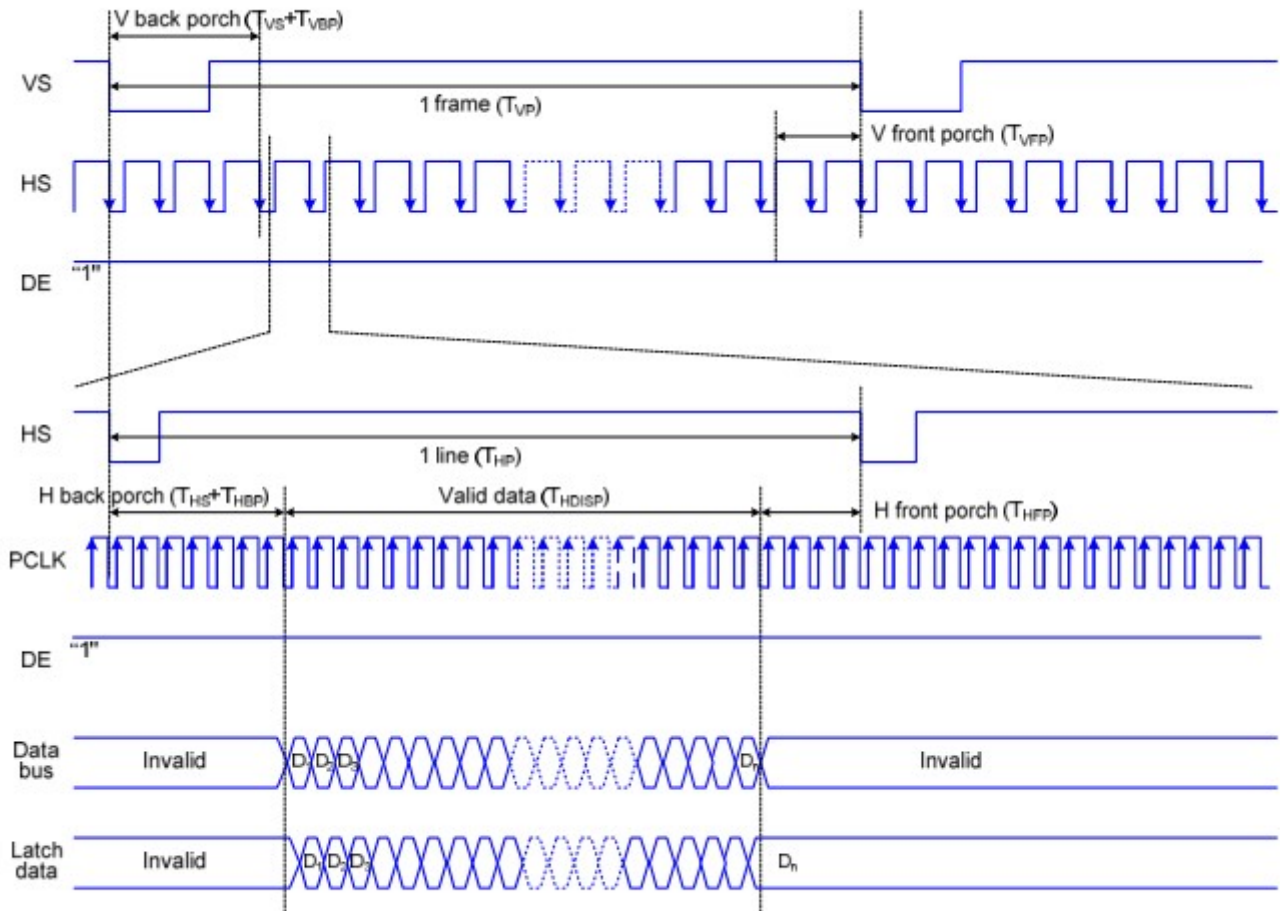

Timing chart of RGB interface HV mode

The following are the functions not available in RGB Input Interface mode.

Function	RGB Interface	I80 System Interface
Partial display	Not available	Available
Scroll function	Not available	Available
Interlaced scan	Not available	Available
Graphics operation function	Not available	Available

VSYNC, HSYNC, and DOTCLK signals must be supplied during a display operation period.

In RGB interface mode, the panel controlling signals are generated from DOTCLK, not the internal clock generated from the internal oscillator.

When switching between the internal operation mode and the external display interface operation mode, follow the sequences below in setting instruction.

In RGB interface mode, the front porch period continues until the next VSYNC input is detected after drawing one frame.

In RGB interface mode, a RAM address is set in the address counter every frame on the falling edge of VSYNC.

IIDWay Technology Co. Ltd

6.5 Power ON/OFF Sequence

VDDI and VDD can be applied in any order.

VDD and VDDI can be power down in any order.

During power off, if LCD is in the Sleep Out mode, VDD and VDDI must be powered down minimum 120msec after RESX has been released.

During power off, if LCD is in the Sleep In mode, VDDI or VDD can be powered down minimum 0msec after RESX has been released.

CSX can be applied at any timing or can be permanently grounded. RESX has priority over CSX.

Note 1: There will be no damage to the display module if the power sequences are not met.

Note 2: There will be no abnormal visible effects on the display panel during the Power On/Off Sequences.

Note 3: There will be no abnormal visible effects on the display between end of Power On Sequence and before receiving Sleep Out command. Also between receiving Sleep In command and Power Off Sequence.

Note 4: If RESX line is not held stable by host during Power On Sequence as defined in the sequence below, then it will be necessary to apply a Hardware Reset (RESX) after Host Power On Sequence is complete to ensure correct operation. Otherwise function is not guaranteed.

The power on/off sequence is illustrated below

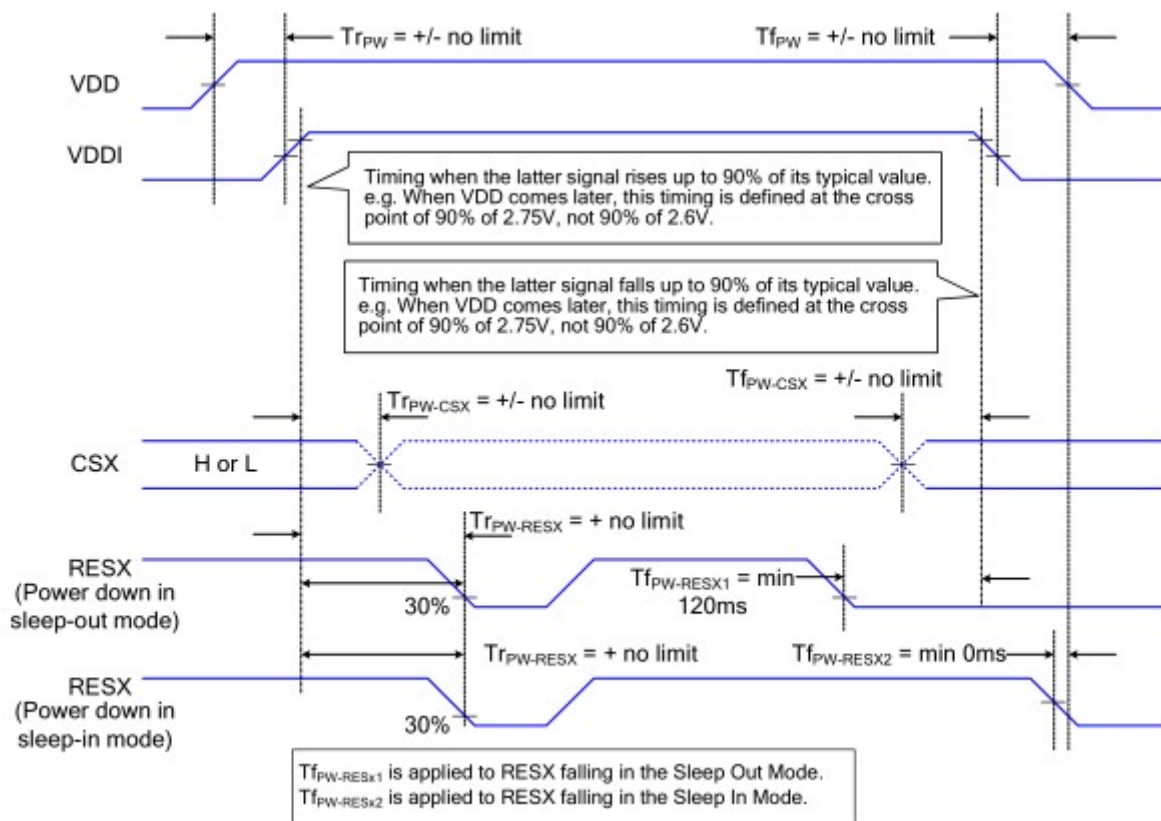

IIDWay Technology Co. Ltd

7. Optical Characteristics

Item	Symbol	Condition	Min.	Typ.	Max.	Unit	Note	
Brightness	Bp	$\theta=0^\circ$	-	300	-	Cd/m ²	1	
Uniformity	ΔBp	$\Phi=0^\circ$	80	-	-	%	1,2	
Viewing Angle	3:00	Cr \geq 10	-	80	-	Deg	3	
	6:00		-	80	-			
	9:00		-	80	-			
	12:00		-	80	-			
Contrast Ratio	Cr	$\theta=0^\circ$	800	1000	-	-	4	
Response Time	T _r +T _f	$\Phi=0^\circ$	-	30	35	ms	5	
Color of CIE Coordinate	W	x	$\theta=0^\circ$ $\Phi=0^\circ$	Typ. -0.05	0.2717	Typ. +0.05	-	1,6
		y			0.2871		-	
	R	x			0.628		-	
		y			0.3393		-	
	G	x			0.3059		-	
		y			0.5801		-	
	B	x			0.1397		-	
		y			0.6401		-	

Note: The parameter is slightly changed by temperature, driving voltage and materiel

Note 1: The data are measured after LEDs are turned on for 5 minutes. LCM displays full white. The brightness is the average value of 9 measured spots. Measurement equipment BM-7 (Φ 5mm)

IIDWay Technology Co. Ltd

Measuring condition:

- Measuring surroundings: Dark room.
- Measuring temperature: $T_a=25\text{ }^\circ\text{C}$.
- Adjust operating voltage to get optimum contrast at the center of the display.

Measured value at the center point of LCD panel after more than 5 minutes while backlight turning on.

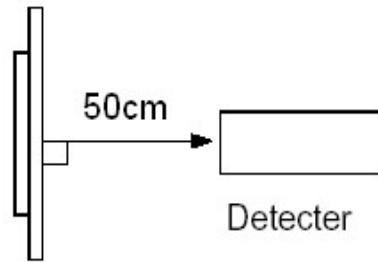

Note 2: The luminance uniformity is calculated by using following formula.

$$\Delta Bp = Bp (\text{Min.}) / Bp (\text{Max.}) \times 100 (\%)$$

$Bp (\text{Max.})$ = Maximum brightness in 9 measured spots

$Bp (\text{Min.})$ = Minimum brightness in 9 measured spots.

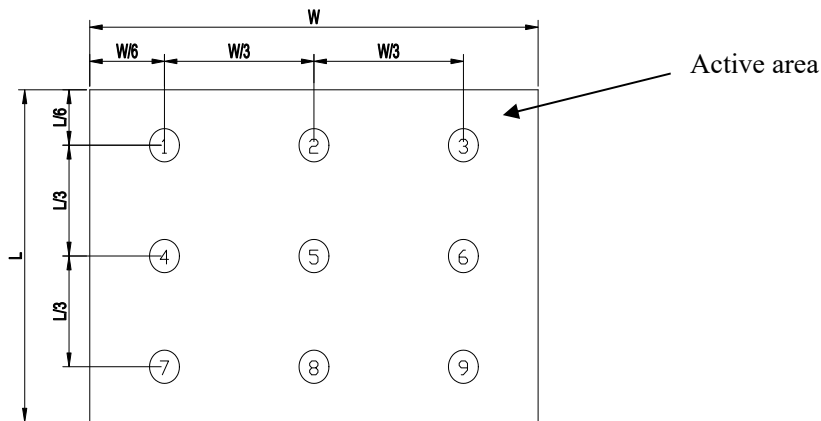

Note 3: The definition of viewing angle:

Refer to the graph below marked by ϑ and ϕ

IIDWay Technology Co. Ltd

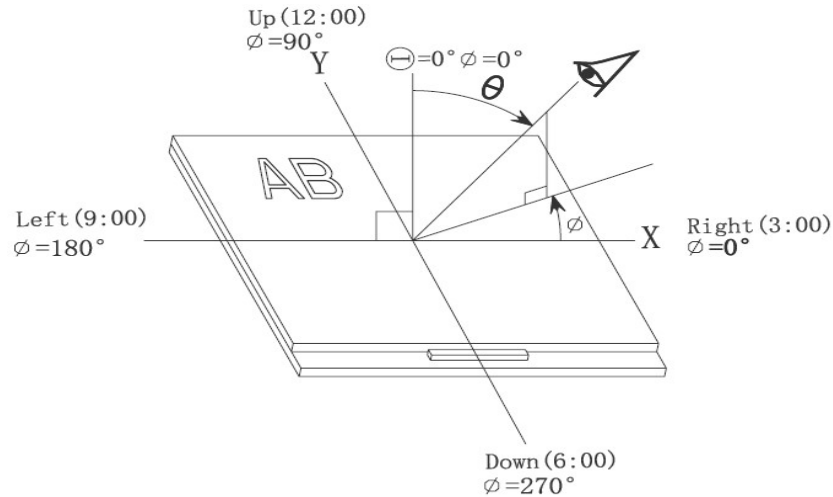

Note 4: Definition of contrast ratio.(Test LCD using DMS501)

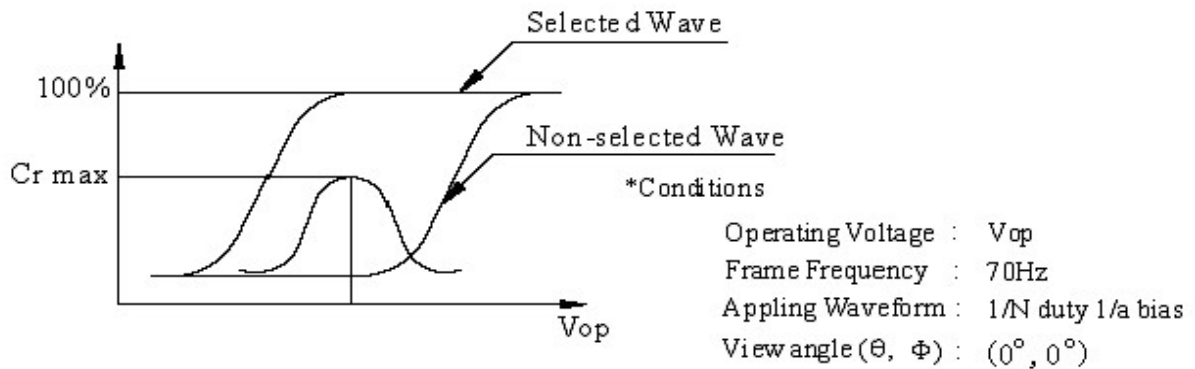

$$\text{Contrast ratio}(Cr) = \frac{\text{Brightness of selected dots}}{\text{Brightness of non-selected dots}}$$

Note 5: Definition of Response time. (Test LCD using DMS501):

The output signals of photo detector are measured when the input signals are changed from "black" to "white"(falling time) and from "white" to "black"(rising time), respectively. The response time is defined as the time interval between the 10% and 90% of amplitudes.Refer to figure as below.

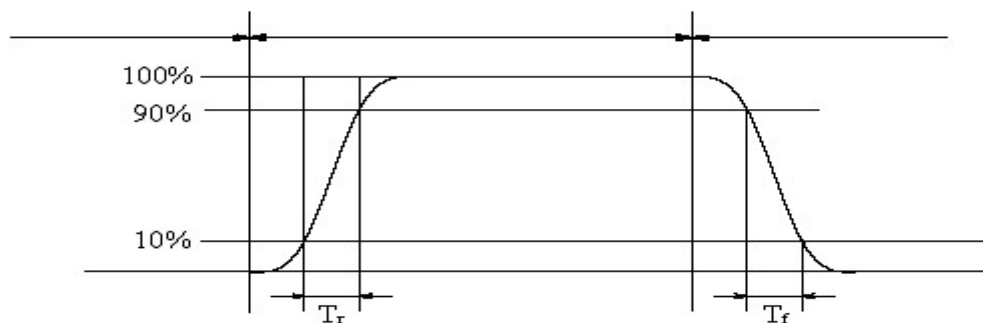

The definition of response time

Note 6: Definition of Color of CIE Coordinate and NTSC Ratio.

IIDWay Technology Co. Ltd

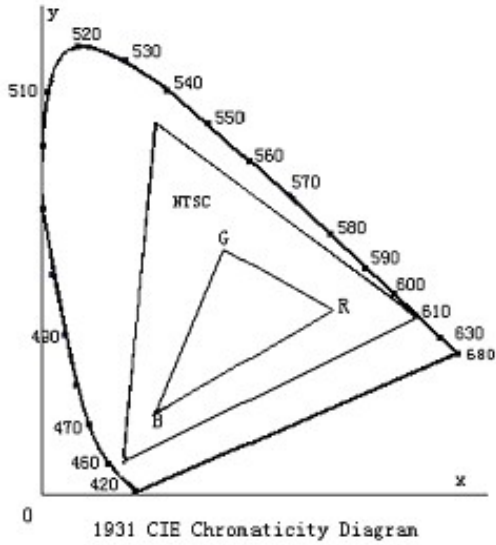

Color gamut:

$$S = \frac{\text{area of RGB triangle}}{\text{area of NTSC triangle}} \times 100\%$$

Note 7: Definition of cross talk.

Cross talk ratio(%) = $\frac{|\text{pattern A Brightness} - \text{pattern B Brightness}|}{\text{pattern A Brightness}} \times 100$

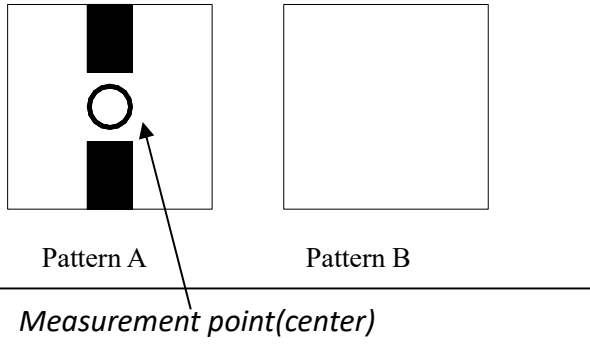

Electric volume value = $3F + / - 3Hex$

IIDWay Technology Co. Ltd

8. Reliability Test Items and Criteria

No	Test Item	Test condition	Criterion
1	High Temperature Storage	80°C±2°C 96H Restore 2H at 25°C Power off	1. After testing, cosmetic and electrical defects should not happen. 2. Total current consumption should not be more than twice of initial value.
2	Low Temperature Storage	-30°C±2°C 96H Restore 2H at 25°C Power off	
3	High Temperature Operation	70°C±2°C 96H Restore 2H at 25°C Power on	
4	Low Temperature Operation	-20°C±2°C 96H Restore 4H at 25°C Power on	
5	High Temperature/Humidity Operation	60°C±2°C 90%RH 96H Power on	
6	Temperature Cycle	-30°C → 80°C 30min 5min 30min after 5 cycle, Restore 2H at 25°C Power off	

Note: Operation: Supply 3.3V for logic system.

The inspection terms after reliability test, as below

ITEM	Inspection
Contrast	CR>50%
IDD	IDD<200%
Brightness	Brightness>60%
Color Tone	Color Tone+/-0,05

IIDWay Technology Co. Ltd

9. Precautions for Use of LCD Modules

9.1 Handling Precautions

9.1.1 *The display panel is made of glass. Do not subject it to a mechanical shock by dropping it from a high place, etc.*

9.1.2 *If the display panel is damaged and the liquid crystal substance inside it leaks out, be sure not to get any in your mouth, if the substance comes into contact with your skin or clothes, promptly wash it off using soap and water.*

9.1.3 *Do not apply excessive force to the display surface or the adjoining areas since this may cause the color tone to vary.*

9.1.4 *The polarizer covering the display surface of the LCD module is soft and easily scratched. Handle this polarizer carefully.*

9.1.5 *If the display surface is contaminated, breathe on the surface and gently wipe it with a soft dry cloth. If still not completely clear, moisten cloth with one of the following solvents:*

— Isopropyl alcohol — Ethyl alcohol

Solvents other than those mentioned above may damage the polarizer. Especially, do not use the following:

— Water — Ketone — Aromatic solvents

9.1.6 *Do not attempt to disassemble the LCD Module.*

9.1.7 *If the logic circuit power is off, do not apply the input signals.*

9.1.8 *To prevent destruction of the elements by static electricity, be careful to maintain an optimum work environment.*

a. Be sure to ground the body when handling the LCD Modules.

b. Tools required for assembly, such as soldering irons, must be properly ground.

c. To reduce the amount of static electricity generated, do not conduct assembly and other work under dry conditions.

d. The LCD Module is coated with a film to protect the display surface. Be care when peeling off this protective film since static electricity may be generated.

IIDWay Technology Co. Ltd

9.2 Storage precautions

9.2.1 *When storing the LCD modules, avoid exposure to direct sunlight or to the light of fluorescent lamps.*

9.2.2 *The LCD modules should be stored under the storage temperature range. If the LCD modules will be stored for a long time, the recommend condition is:*

Temperature : 0°C ~ 40°C

Relatively humidity: ≤80%

9.2.3 *The LCD modules should be stored in the room without acid, alkali and harmful gas.*

9.3 *The LCD modules should be no falling and violent shocking during transportation, and also should avoid excessive press, water, damp and sunshine.*

END