

IIDWay Technology Co. Ltd

PRODUCT SPECIFICATIONS

For Customer: _____

: APPROVAL FOR SPECIFICATION

Customer Model No. _____

: APPROVAL FOR SAMPLE

Module No.: GZ70133-DIT070TH

Date : 2022-01-08

Table of Contents

No.	Item	Page
1	Cover Sheet(Table of Contents)	
2	Revision Record	
3	General Specifications	
4	Outline Drawing	
5	Absolute Maximum Ratings	
6	Electrical Specifications	
7	Optical Characteristics	
8	Reliability Test Items and Criteria	
9	Precautions for Use of LCD Modules	

For Customer's Acceptance:

Approved By	Comment

PREPARED	CHECKED	VERIFIED BY QA DEPT	VERIFIED BY R&D DEPT
NIKOLA			

IIDWay Technology Co. Ltd

3. General Specifications

GZ70133-DIT070TH is a TFT-LCD module. It is composed of a TFT-LCD panel, driver IC, FPC, a back light, and CTP unit. The 7.0" display area contains 280 x (RGB) x 1424 pixels and can display up to 16.7M colors. This product accords with RoHS environmental criterion.

Item	Contents	Unit	Note
LCD Type	TFT	-	
Display color	16.7M	color	1
Viewing Direction	ALL	O'Clock	
Operating temperature	-20~+70	°C	
Storage temperature	-30~+80	°C	
Module size	38.20X181.47X3.40	mm	2
Active Area(W×H)	33.60X170.88	mm	
Number of Dots	280×1424	dots	
IC Controller	OTA7290N	V	
Power Supply Voltage	3.3	V	
Backlight	8SLEDs	pcs	
Weight	---	g	
Interface	MIPI	-	

Note 1: Color temperature is slightly changed

by temperature and driving voltage.

Note 2: With TFT+BL.

4.Outline.Drawing

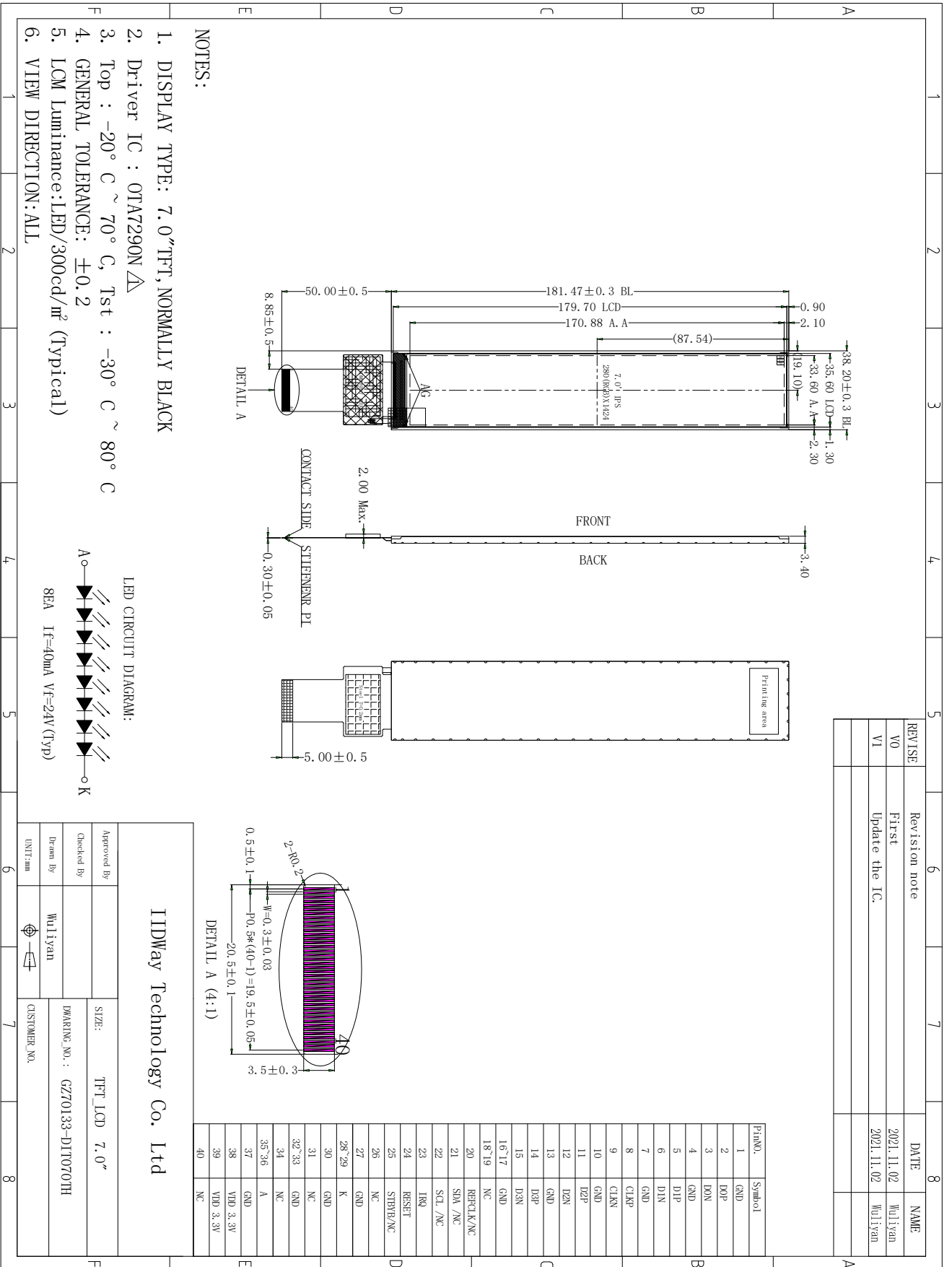

IIDWay Technology Co. Ltd

5. Absolute Maximum Ratings($T_a=25^\circ\text{C}$)

5.1 Electrical Absolute Maximum Ratings.($V_{ss}=0\text{V}$, $T_a=25^\circ\text{C}$)

Item	Symbol	Min.	Max.	Unit	Note
Power Supply Voltage	VDD	-0.5	4.0	V	1, 2

Notes:

1. If the module is above these absolute maximum ratings. It may become permanently damaged.
Using the module within the following electrical characteristic conditions are also exceeded, the module will malfunction and cause poor reliability.
2. $V_{CC} > GND$ must be maintained.
3. Please be sure users are grounded when handing LCD Module.

5.2 Environmental Absolute Maximum Ratings.

Item	Storage		Operating		Note
	MIN.	MAX.	MIN.	MAX.	
Ambient Temperature	-30°C	80°C	-20°C	70°C	1,2
Humidity	-	-	-	-	3

1. The response time will become lower when operated at low temperature.
2. Background color changes slightly depending on ambient temperature.
The phenomenon is reversible.
3. $T_a \leq 40^\circ\text{C}$: 85%RH MAX.
 $T_a > 40^\circ\text{C}$: Absolute humidity must be lower than the humidity of 85%RH at 40°C .

6. Electrical Specifications

6.1 Electrical characteristics($V_{ss}=0\text{V}$, $T_a=25^\circ\text{C}$)

Parameter	Symbol	Condition	Min	Typ	Max	Unit	Note
Power supply	VDD	$T_a=25^\circ\text{C}$	2.7	3.3	3.6	V	

IIDWay Technology Co. Ltd

Input voltage	‘H’	V _{IH}	T _a =25°C	0.7V _{CC}	-	V _{CC}	V	
---------------	-----	-----------------	----------------------	--------------------	---	-----------------	---	--

Pin No.	Symbol	I/O	Function
---------	--------	-----	----------

Item	Symbol	Condition	Min	Typ	Max	Unit	Note
Uniformity	Δ Bp	I _f =40mA	75	80	-	%	
Life Time	time	I _f =40mA	-	20K	-	hours	1

6.2 LED backlight specification(VSS=0V ,T_a=25 °C)

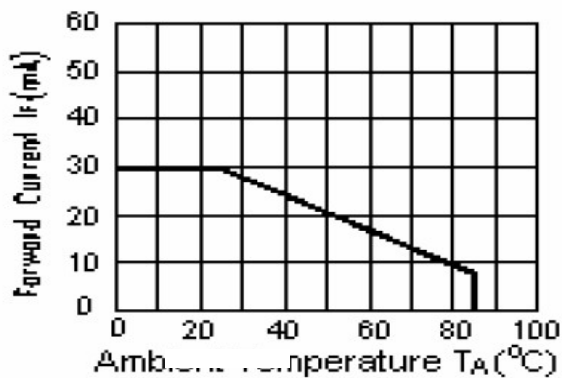

Note 1: Brightness to be decreased to 50% of the initial value at ambient temperature T_A=25 °C

IIDWay Technology Co. Ltd

1	GND	P	Connect to Ground.
2	D0P	I	Positive polarity of low voltage differential data signal(Data lane 0).
3	D0N	I	Negative polarity of low voltage differential data signal(Data lane 0).
4	GND	P	Connect to Ground.
5	D1P	I	Positive polarity of low voltage differential data signal(Data lane 1).
6	D1N	I	Negative polarity of low voltage differential data signal(Data lane 1).
7	GND	P	Connect to Ground.
8	CLKP	I	Positive polarity of low voltage differential clock signal.
9	CLKN	I	Negative polarity of low voltage differential clock signal.
10	GND	P	Connect to Ground.
11	D2P	I	Positive polarity of low voltage differential data signal(Data lane 2).
12	D2N	I	Negative polarity of low voltage differential data signal(Data lane 2).
13	GND	P	Connect to Ground.
14	D3P	I	Positive polarity of low voltage differential data signal(Data lane 3).
15	D3N	I	Negative polarity of low voltage differential data signal(Data lane 3).
16-17	GND	P	Connect to Ground.
18-19	NC	-	No Connection
20	REFCLK/NC	I/-	No Connection
21	SDA/NC	I/-	Serial in/out signal pin/No Connection
22	SCL/NC	I/-	Serial interface clock pin/No Connection
23	IRQ	-	No Connection
24	RESET	I	Global reset signal input pin
25	STBYB/NC	I/-	Standby mode control pin/No Connection
26	NC	-	No Connection
27	GND	P	Connect to Ground.
28-29	K	P	LED back light(Cathode)
30	GND	P	Connect to Ground.
31	NC	-	No Connection
32-33	GND	P	Connect to Ground.
34	NC	-	No Connection
35-36	A	P	LED back light(Anode)
37	GND	P	Connect to Ground.
38	VDD 3.3V	P	Analog or digital supply voltage
39	VDD 3.3V	P	Analog or digital supply voltage
40	NC	-	No Connection

6.3 Interface signals

IIDWay Technology Co. Ltd

7. Optical Characteristics

Item	Symbol	Condition	Min.	Typ.	Max.	Unit	Note	
Brightness	Bp	$\theta=0^\circ$	-	300	-	Cd/m ²	1	
Uniformity	ΔBp	$\Phi=0^\circ$	75	80	-	%	1,2	
Viewing Angle	3:00	Cr \geq 10	75	80	-	Deg	3	
	6:00		75	80	-			
	9:00		75	80	-			
	12:00		75	80	-			
Contrast Ratio	Cr	$\theta=0^\circ$ $\Phi=0^\circ$	800	1000	-	-	4	
Response Time	T _r		-	30	40	ms	5	
	T _f							
Color of CIE Coordinate	W	x	$\theta=0^\circ$ $\Phi=0^\circ$	Typ. -0.05	Typ. +0.05	-	1,6	
		y				-		
	R	x				0.305		-
		y				0.315		-
	G	x				0.644		-
		y				0.332		-
	B	x				0.324		-
		y				0.566		-
	x	0.137	-					
	y	0.125	-					
NTSC Ratio	S		60	-	%			

Note: The parameter is slightly changed by temperature, driving voltage and materiel

Note 1: The data are measured after LEDs are turned on for 5 minutes. LCM displays full white. The brightness is the average value of 9 measured spots. Measurement equipment PR-705 (Φ8mm)

Measuring condition:

- Measuring surroundings: Dark room.
- Measuring temperature: Ta=25°C.
- Adjust operating voltage to get optimum contrast at the center of the display.

Measured value at the center point of LCD panel after more than 5 minutes while backlight turning on.

IIDWay Technology Co. Ltd

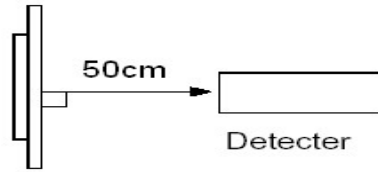

Note 2: The luminance uniformity is calculated by using following formula.

$$\Delta B_p = B_p (\text{Min.}) / B_p (\text{Max.}) \times 100 (\%)$$

$B_p (\text{Max.})$ = Maximum brightness in 9 measured spots

$B_p (\text{Min.})$ = Minimum brightness in 9 measured spots.

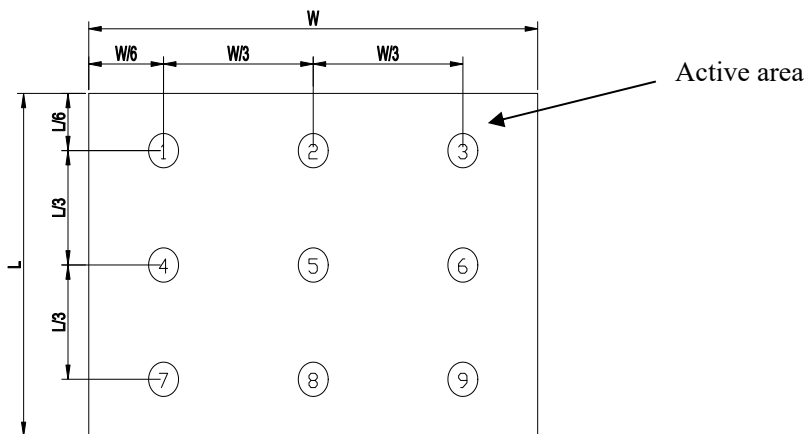

Note 3: The definition of viewing angle:

Refer to the graph below marked by θ and Φ

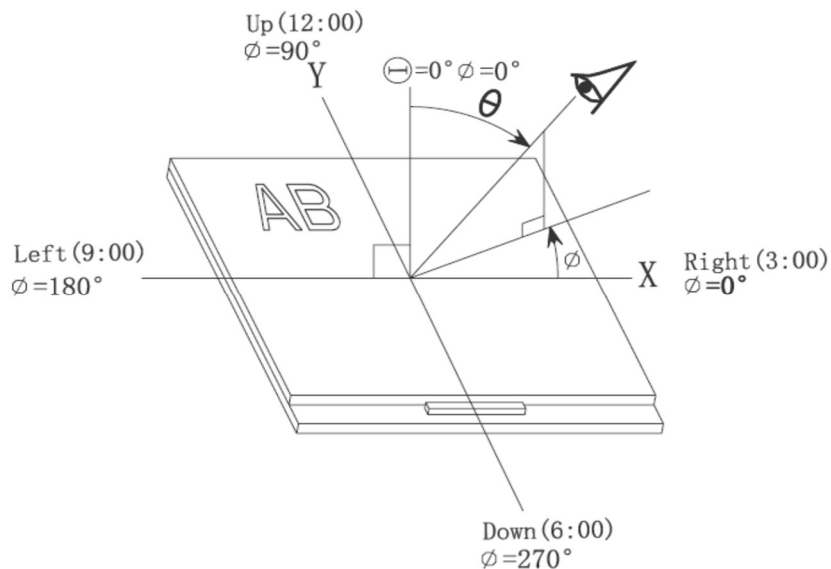

Note 4: Definition of contrast ratio. (Test LCD using DMS501)

IIDWay Technology Co. Ltd

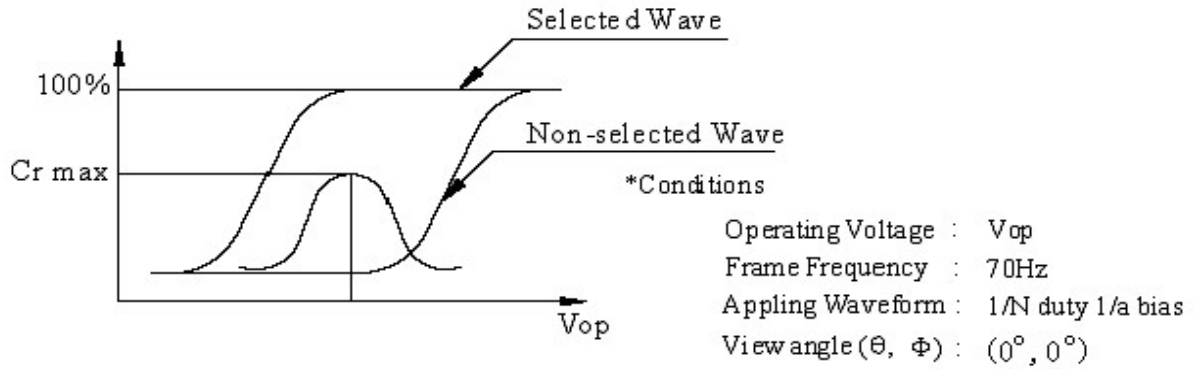

$$\text{Contrast ratio}(Cr) = \frac{\text{Brightness of selected dots}}{\text{Brightness of non-selected dots}}$$

Note 5: Definition of Response time. (Test LCD using DMS501):

The output signals of photo detector are measured when the input signals are changed from "black" to "white" (falling time) and from "white" to "black" (rising time), respectively. The response time is defined as the time interval between the 10% and 90% of amplitudes. Refer to figure as below.

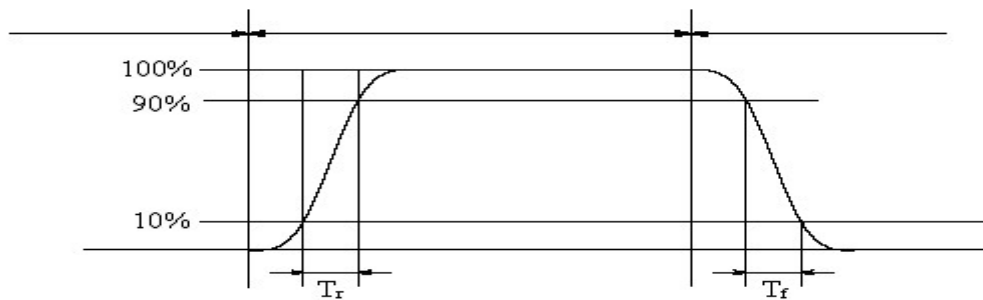

The definition of response time

Note 6: Definition of Color of CIE Coordinate and NTSC Ratio.

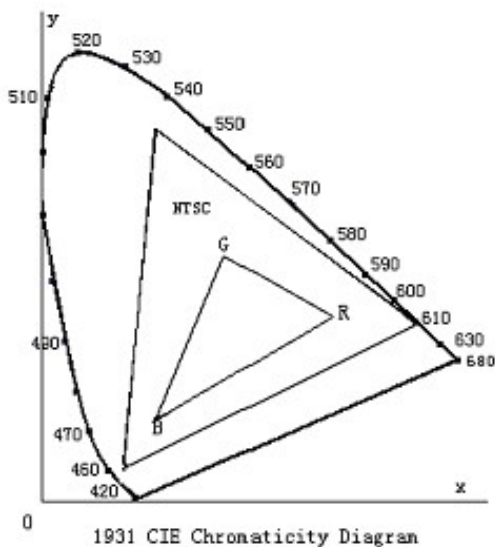

Color gamut:

$$S = \frac{\text{area of RGB triangle}}{\text{area of NTSC triangle}} \times 100\%$$

IIDWay Technology Co. Ltd

Note 7: Definition of cross talk.

$Cross\ talk\ ratio(\%) = \frac{|pattern\ A\ Brightness - pattern\ B\ Brightness|}{pattern\ A\ Brightness} * 100$

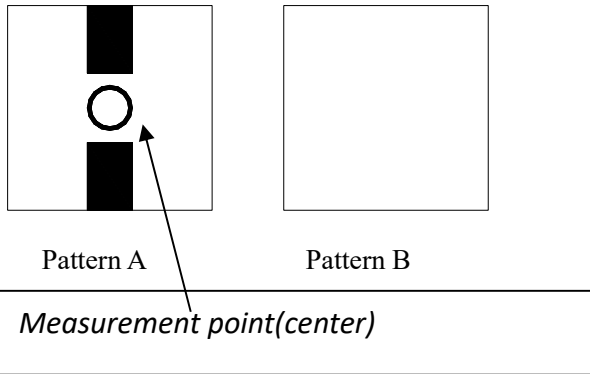

Electric volume value=3F+/-3Hex

IIDWay Technology Co. Ltd

8. Reliability Test Items and Criteria

Test Item	Test condition	Remark
High Temperature Storage	Ta = 80°C 96hrs	Note1,Note4
Low Temperature Storage	Ta = -30°C 96hrs	Note1,Note4
High Temperature Operation	Ta = 70°C 96hrs	Note2,Note4
Low Temperature Operation	Ta = -20°C 96hrs	Note1,Note4
Operation at High Temperature/Humidity	+60°C, 90%RH 96HR	Note4
Thermal Shock	-30°C/30 min ~ +80°C/30 min for a total 100 cycles, Start with cold temperature and endwith high temperature.	Note4
Vibration Test	Frequency range:10~55Hz Stroke:1.5mm Sweep:10Hz~55Hz~10Hz 2 hours for each direction of X. Y. Z. (6 hours for total)	
Mechanical Shock	100G 6ms,±X, ±Y, ±Z 3 times for each direction	
Package Vibration Test	Random Vibration : 0.015G*G/Hz from 5-200HZ, -6dB/Octave from 200-500HZ 2 hours for each direction of X. Y. Z. (6 hours for total)	
Package Drop Test	Height:60cm 1 corner, 3 edges, 6 surfaces	
Electro Static Discharge	±2KV, Human Body Mode, 100pF/1500Ω	

Note 1: Ta is the ambient temperature of samples.

Note 2: Ts is the temperature of panel's surface.

Note 3: In the standard condition, there shall be no practical problem that may affect the display function. After the reliability test, the product only guarantees operation, but don't guarantee all of the cosmetic specification.

Note 4: Before cosmetic and function test, the product must have enough recovery time, at least 2 hours at room temperature.

IIDWay Technology Co. Ltd

9. Precautions for Use of LCD Modules

9.1 Handling Precautions

9.1.1 *The display panel is made of glass. Do not subject it to a mechanical shock by dropping it from a high place, etc.*

9.1.2 *If the display panel is damaged and the liquid crystal substance inside it leaks out, be sure not to get any in your mouth, if the substance comes into contact with your skin or clothes, promptly wash it off using soap and water.*

9.1.3 *Do not apply excessive force to the display surface or the adjoining areas since this may cause the color tone to vary.*

9.1.4 *The polarizer covering the display surface of the LCD module is soft and easily scratched. Handle this polarizer carefully.*

9.1.5 *If the display surface is contaminated, breathe on the surface and gently wipe it with a soft dry cloth. If still not completely clear, moisten cloth with one of the following solvents:*

— *Isopropyl alcohol* — *Ethyl alcohol*

Solvents other than those mentioned above may damage the polarizer. Especially, do not use the following:

— *Water* — *Ketone* — *Aromatic solvents*

9.1.6 *Do not attempt to disassemble the LCD Module.*

9.1.7 *If the logic circuit power is off, do not apply the input signals.*

9.1.8 *To prevent destruction of the elements by static electricity, be careful to maintain an optimum work environment.*

a. Be sure to ground the body when handling the LCD Modules.

b. Tools required for assembly, such as soldering irons, must be properly ground.

c. To reduce the amount of static electricity generated, do not conduct assembly and other work under dry conditions.

d. The LCD Module is coated with a film to protect the display surface. Be care when peeling off this protective film since static electricity may be generated.

IIDWay Technology Co. Ltd

9.2 Storage precautions

9.2.1 *When storing the LCD modules, avoid exposure to direct sunlight or to the light of fluorescent lamps.*

9.2.2 *The LCD modules should be stored under the storage temperature range. If the LCD modules will be stored for a long time, the recommend condition is:*

Temperature : 0°C ~ 40°C

Relatively humidity: ≤80%

9.2.3 *The LCD modules should be stored in the room without acid, alkali and harmful gas.*

9.3 *The LCD modules should be no falling and violent shocking during transportation, and also should avoid excessive press, water, damp and sunshine.*

END
