

IIDWay Technology Co. Ltd

PRODUCT SPECIFICATIONS

For Customer: _____ : APPROVAL FOR SPECIFICATION

Customer Model No.: _____ : APPROVAL FOR SAMPLE

Module No.: GZ70113-DIT024QV Date : 2023-11-13

Table of Contents

No.	Item	Page
1	Cover Sheet(Table of Contents)	
2	Revision Record	
3	General Specifications	
4	Outline Drawing	
5	Absolute Maximum Ratings	
6	Electrical Specifications	
7	Optical Characteristics	
8	Reliability Test Items and Criteria	
9	Precautions for Use of LCD Modules	

For Customer's Acceptance:

Approved By	Comment

PREPARED	CHECKED	APPROVER

IIDWay Technology Co. Ltd

3. General Specifications

GZ70113-DIT024QV is a TFT-LCD module. It is composed of a TFT-LCD panel, driver IC, FPC, a back light unit. The 2.4" display area contains 240x320 pixels and can display up to 262K colors. This product accords with RoHS environmental criterion.

Item	Contents	Unit	Note
LCD Type	TFT	-	
Display color	262K		
Viewing Direction	ALL	O'Clock	
Operating temperature	-20~+70	°C	
Storage temperature	-30~+80	°C	
Module size	2.4	inch	
Active Area(W×H)	36.72X48.96	mm	
Number of Dots	240×320	dots	
Controller	ILI9341V	-	
Power Supply Voltage	2.8	V	
Outline Dimensions	42.72×59.46×2.45	mm	
Backlight	2S3P-LEDs (white)	pcs	
Weight	---	g	
Interface	RGB/MCU/SPI	-	

IIDWay Technology Co. Ltd

5. Absolute Maximum Ratings(Ta=25°C)

5.1 Electrical Absolute Maximum Ratings.(Vss=0V ,Ta=25°C)

Item	Symbol	Min.	Max.	Unit	Note
Supply Voltage(Logic)	V _{Cl}	-0.3	4.6	V	1, 2
Supply Voltage(Digital)	IO _{VCC}	-0.3	4.6	V	1, 2

Notes:

1. If the module is above these absolute maximum ratings. It may become permanently damaged. Using the module within the following electrical characteristic conditions are also exceeded, the module will malfunction and cause poor reliability.
2. V_{DD} > V_{SS} must be maintained.
3. Please be sure users are grounded when handing LCD Module.

5.2 Environmental Absolute Maximum Ratings.

Item	Storage		Operating		Note
	MIN.	MAX.	MIN.	MAX.	
Ambient Temperature	-30°C	80°C	-20°C	70°C	1,2
Humidity	-	-	-	-	3

1. The response time will become lower when operated at low temperature.
2. Background color changes slightly depending on ambient temperature.
The phenomenon is reversible.
3. Ta<=40°C:85%RH MAX.

Ta>=40°C:Absolute humidity must be lower than the humidity of 85%RH at 40°C.

IIDWay Technology Co. Ltd

6. Electrical Specifications and Instruction Code

6.1 Electrical characteristics(V_{SS}=0V ,T_a=25°C)

Parameter	Symbol	Condition	Min	Typ	Max	Unit	Note
Voltage(Logic)	V _{CI}	T _a =25°C	2.6	2.8	3.3	V	
Voltage(Digital)	IO _{VCC}	T _a =25°C	1.65	2.8	3.3	V	
Input voltage	'H'	V _{IH}	V _{CI} =2.8V	0.8V _{CI}	-	V _{CI}	V
	'L'	V _{IL}	V _{CI} =2.8V	0	-	0.2V _{CI}	V
Current Consumption	I _{CI1}	Normal mode	-	8	13	mA	
	I _{CI2}	Sleep mode	-	0.1	-	mA	

Note: 1. Tested in 1×1 chessboard pattern.

6.2 LED backlight specification(V_{SS}=0V ,T_a=25°C)

Item	Symbol	Condition	Min	Typ	Max	Unit	Note
Supply voltage	V _f	I _f =20X3mA	-	6.0	-	V	
Uniformity	ΔBp	I _f =20X3mA	80	-	-	%	

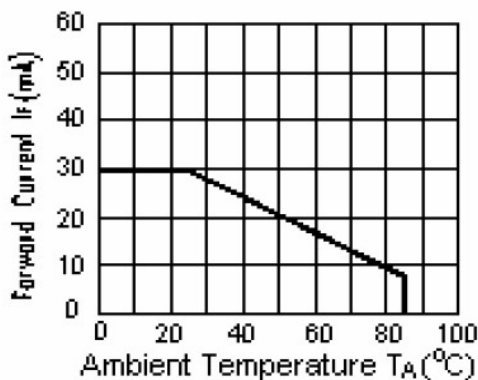

I_{LED} VS TEMP

6.3 Interface signals

IIDWay Technology Co. Ltd

Pin No.	Symbol	I/O	Function																																																																																													
1	NC	-	No connection																																																																																													
2	IOVCC	P	Digital I/O pad power supply																																																																																													
3-20	DB17-DB0	I	data bus																																																																																													
21	SDA(SDI)	I	When IM3=0, serves as a serial in/out signal.(SDA) When IM3="1", serves as a serial in signal.(SDI) The data is applied on the rising edge of the SCL signal. If ont used, fix this pin at IOVCC or GND																																																																																													
22	DOTCLK	I	Data clock signal for RGB interface operation																																																																																													
23	DE	I	Data enable signal for RGB interface operation																																																																																													
24	HSYNC	I	Line sync signal																																																																																													
25	VSYNC	I	Frame sync signal																																																																																													
26	RD	I	8080-I/8080-II system: serves as a read signal an MCU read data at the rising edge.																																																																																													
27	WR(D/C)	I	8080-I/8080-II system: serves as a write signal an MCU write data at the rising edge. 4-line system:serves as Data or Command select. In serial interface "2-data-lane data" transfers mode, serves as a second data pin																																																																																													
28	DC(SCL)	I	(DC)This pin is used to select "Data or Command" in the parallel interface SCL: Serial data clock in serial bus system																																																																																													
29	CS	I	Chip select signal																																																																																													
30	RESET	I	System Reset																																																																																													
31-34	IM0-IM3	I	System interface select. <table border="1" style="width: 100%; border-collapse: collapse; text-align: center;"> <thead> <tr> <th rowspan="2">IM3</th> <th rowspan="2">IM2</th> <th rowspan="2">IM1</th> <th rowspan="2">IM0</th> <th rowspan="2">MCU-Interface Mode</th> <th colspan="2">DB Pin in use</th> </tr> <tr> <th>Register/Content</th> <th>GRAM</th> </tr> </thead> <tbody> <tr> <td>0</td> <td>0</td> <td>0</td> <td>0</td> <td>80 MCU 8-bit bus interface I</td> <td>D[7:0]</td> <td>D[7:0]</td> </tr> <tr> <td>0</td> <td>0</td> <td>0</td> <td>1</td> <td>80 MCU 16-bit bus interface I</td> <td>D[7:0]</td> <td>D[15:0]</td> </tr> <tr> <td>0</td> <td>0</td> <td>1</td> <td>0</td> <td>80 MCU 9-bit bus interface I</td> <td>D[7:0]</td> <td>D[8:0]</td> </tr> <tr> <td>0</td> <td>0</td> <td>1</td> <td>1</td> <td>80 MCU 16-bit bus interface I</td> <td>D[7:0]</td> <td>D[17:0]</td> </tr> <tr> <td>0</td> <td>1</td> <td>0</td> <td>1</td> <td>3-wire 9-bit data serial interface I</td> <td colspan="2">SDA: In/OUT</td> </tr> <tr> <td>0</td> <td>1</td> <td>1</td> <td>0</td> <td>4-wire 8-bit data serial interface I</td> <td colspan="2">SDA: In/OUT</td> </tr> <tr> <td>1</td> <td>0</td> <td>0</td> <td>0</td> <td>80 MCU 16-bit bus interface II</td> <td>D[8:1]</td> <td>D[17:10], D[8:1]</td> </tr> <tr> <td>1</td> <td>0</td> <td>0</td> <td>1</td> <td>80 MCU 9-bit bus interface II</td> <td>D[17:10]</td> <td>D[17:10]</td> </tr> <tr> <td>1</td> <td>0</td> <td>1</td> <td>0</td> <td>80 MCU 16-bit bus interface II</td> <td>D[8:1]</td> <td>D[17:0]</td> </tr> <tr> <td>1</td> <td>0</td> <td>1</td> <td>1</td> <td>80 MCU 9-bit bus interface II</td> <td>D[17:10]</td> <td>D[17:9]</td> </tr> <tr> <td>1</td> <td>1</td> <td>0</td> <td>1</td> <td>3-wire 9-bit data serial interface II</td> <td colspan="2">SDI: In SDO: Out</td> </tr> <tr> <td>1</td> <td>1</td> <td>1</td> <td>0</td> <td>4-wire 8-bit data serial interface II</td> <td colspan="2">SDI: In SDO: Out</td> </tr> </tbody> </table>	IM3	IM2	IM1	IM0	MCU-Interface Mode	DB Pin in use		Register/Content	GRAM	0	0	0	0	80 MCU 8-bit bus interface I	D[7:0]	D[7:0]	0	0	0	1	80 MCU 16-bit bus interface I	D[7:0]	D[15:0]	0	0	1	0	80 MCU 9-bit bus interface I	D[7:0]	D[8:0]	0	0	1	1	80 MCU 16-bit bus interface I	D[7:0]	D[17:0]	0	1	0	1	3-wire 9-bit data serial interface I	SDA: In/OUT		0	1	1	0	4-wire 8-bit data serial interface I	SDA: In/OUT		1	0	0	0	80 MCU 16-bit bus interface II	D[8:1]	D[17:10], D[8:1]	1	0	0	1	80 MCU 9-bit bus interface II	D[17:10]	D[17:10]	1	0	1	0	80 MCU 16-bit bus interface II	D[8:1]	D[17:0]	1	0	1	1	80 MCU 9-bit bus interface II	D[17:10]	D[17:9]	1	1	0	1	3-wire 9-bit data serial interface II	SDI: In SDO: Out		1	1	1	0	4-wire 8-bit data serial interface II	SDI: In SDO: Out	
IM3	IM2	IM1	IM0						MCU-Interface Mode	DB Pin in use																																																																																						
				Register/Content	GRAM																																																																																											
0	0	0	0	80 MCU 8-bit bus interface I	D[7:0]	D[7:0]																																																																																										
0	0	0	1	80 MCU 16-bit bus interface I	D[7:0]	D[15:0]																																																																																										
0	0	1	0	80 MCU 9-bit bus interface I	D[7:0]	D[8:0]																																																																																										
0	0	1	1	80 MCU 16-bit bus interface I	D[7:0]	D[17:0]																																																																																										
0	1	0	1	3-wire 9-bit data serial interface I	SDA: In/OUT																																																																																											
0	1	1	0	4-wire 8-bit data serial interface I	SDA: In/OUT																																																																																											
1	0	0	0	80 MCU 16-bit bus interface II	D[8:1]	D[17:10], D[8:1]																																																																																										
1	0	0	1	80 MCU 9-bit bus interface II	D[17:10]	D[17:10]																																																																																										
1	0	1	0	80 MCU 16-bit bus interface II	D[8:1]	D[17:0]																																																																																										
1	0	1	1	80 MCU 9-bit bus interface II	D[17:10]	D[17:9]																																																																																										
1	1	0	1	3-wire 9-bit data serial interface II	SDI: In SDO: Out																																																																																											
1	1	1	0	4-wire 8-bit data serial interface II	SDI: In SDO: Out																																																																																											
35	NC	-	No connection																																																																																													
36	GND	P	Ground.																																																																																													
37	VCI	P	Power supply																																																																																													
38	NC	P	No connection																																																																																													
39	LED-A	P	LED back light(Anode)																																																																																													
40	LED-K	P	LED back light(Cathode)																																																																																													

IIDWay Technology Co. Ltd

7. Optical Characteristics

Item	Symbol	Condition	Min.	Typ.	Max.	Unit	Note
Brightness	Bp	$\theta=0^\circ$	425	500	-	Cd/m ²	1
Uniformity	ΔBp	$\Phi=0^\circ$	80	-	-	%	1,2
Viewing Angle	3:00	Cr \geq 10	-	80	-	Deg	3
	6:00		-	80	-		
	9:00		-	80	-		
	12:00		-	80	-		
Contrast Ratio	Cr	$\theta=0^\circ$ $\Phi=0^\circ$	640	800	-	-	4
Response Time	T _r		-	10		ms	5
	T _f		-	10		ms	
Color of CIE Coordinate	W	x	$\theta=0^\circ$ $\Phi=0^\circ$	0.31		-	1,6
		y		0.33		-	
	R	x		0.51		-	
		y		0.34		-	
	G	x		0.31		-	
		y		0.56		-	
	B	x		0.15		-	
		y		0.14		-	
NTSC Ratio	S	50	60	-	%		

Note: The parameter is slightly changed by temperature, driving voltage and materiel

Note 1: The data are measured after LEDs are turned on for 5 minutes. LCM displays full white.

The brightness is the average value of 9 measured spots. Measurement equipment BM-7 (Φ 5mm)

Measuring condition:

- Measuring surroundings: Dark room.
- Measuring temperature: Ta=25°C.

IIDWay Technology Co. Ltd

- Adjust operating voltage to get optimum contrast at the center of the display.

Measured value at the center point of LCD panel after more than 5 minutes while backlight turning on.

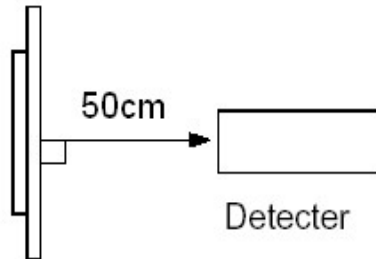

Note 2: The luminance uniformity is calculated by using following formula.

$$\Delta Bp = Bp (\text{Min.}) / Bp (\text{Max.}) \times 100 (\%)$$

$Bp (\text{Max.})$ = Maximum brightness in 9 measured spots

$Bp (\text{Min.})$ = Minimum brightness in 9 measured spots.

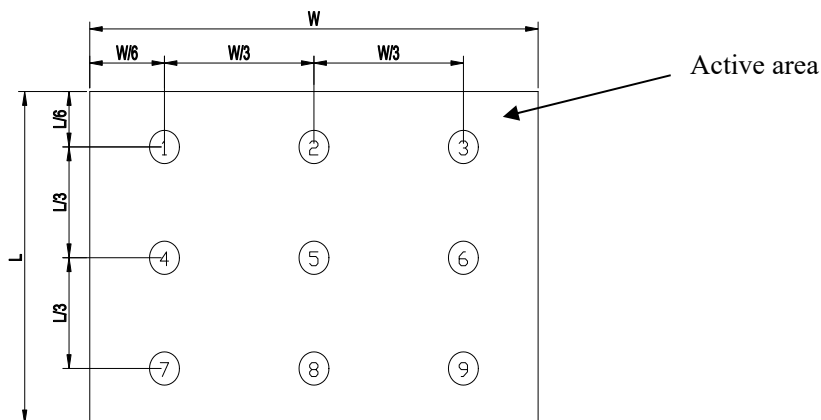

Note 3: The definition of viewing angle:

Refer to the graph below marked by θ and Φ

IIDWay Technology Co. Ltd

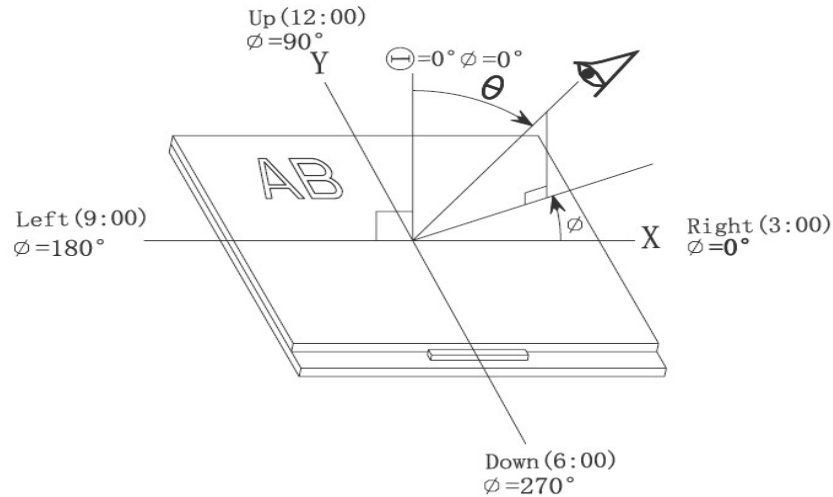

Note 4: Definition of contrast ratio.(Test LCD using DMS501)

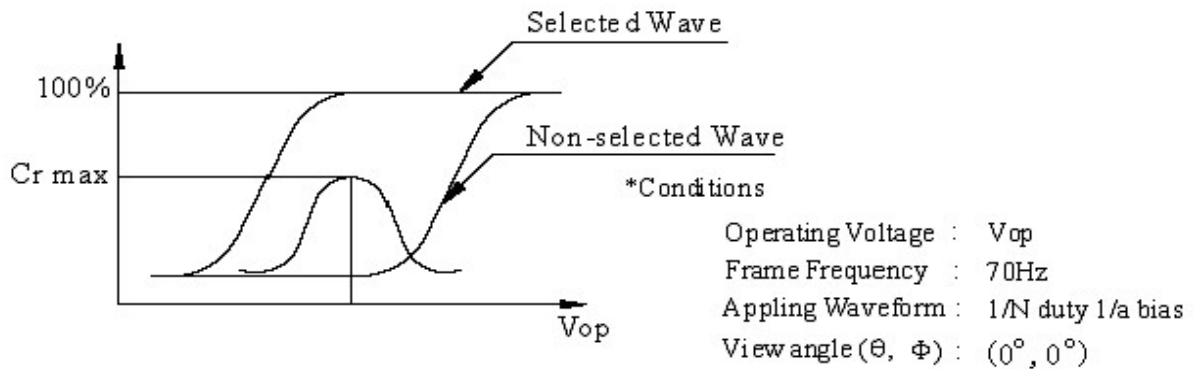

$$\text{Contrast ratio}(Cr) = \frac{\text{Brightness of selected dots}}{\text{Brightness of non-selected dots}}$$

Note 5: Definition of Response time. (Test LCD using DMS501):

The output signals of photo detector are measured when the input signals are changed from “black” to “white”(falling time) and from “white” to “black”(rising time), respectively. The response time is defined as the time interval between the 10% and 90% of amplitudes.Refer to figure as below.

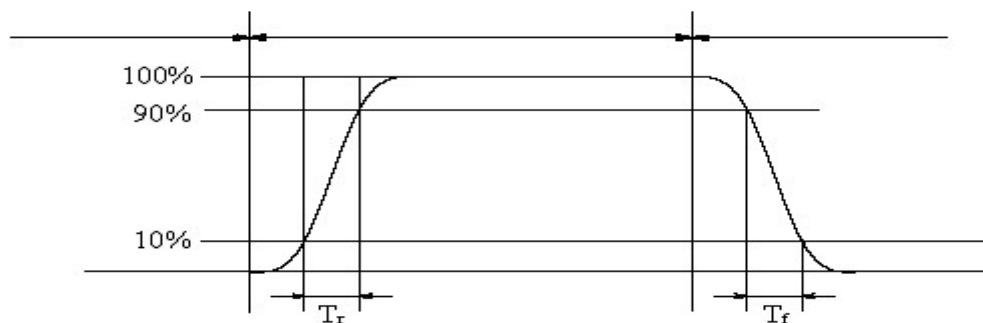

The definition of response time

Note 6: Definition of Color of CIE Coordinate and NTSC Ratio.

IIDWay Technology Co. Ltd

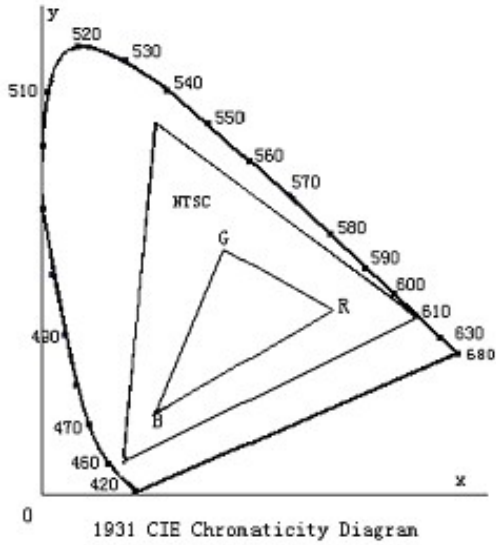

Color gamut:

$$S = \frac{\text{area of RGB triangle}}{\text{area of NTSC triangle}} \times 100\%$$

Note 7: Definition of cross talk.

Cross talk ratio(%)=|pattern A Brightness-pattern B Brightness|/pattern A Brightness*100

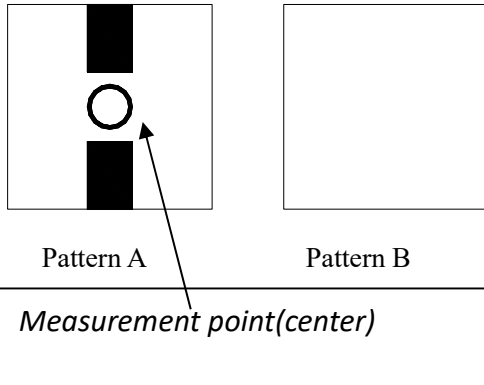

Electric volume value=3F+/-3Hex

IIDWay Technology Co. Ltd

8. Reliability Test Items and Criteria

No	Test Item	Test condition	Criterion
1	High Temperature Storage	80°C±2°C 96H Restore 2H at 25°C Power off	1. After testing, cosmetic and electrical defects should not happen. 2. Total current consumption should not be more than twice of initial value.
2	Low Temperature Storage	-30°C±2°C 96H Restore 2H at 25°C Power off	
3	High Temperature Operation	70°C±2°C 96H Restore 2H at 25°C Power on	
4	Low Temperature Operation	-20°C±2°C 96H Restore 4H at 25°C Power on	
5	High Temperature/Humidity Operation	60°C±2°C 90%RH 96H Power on	
6	Temperature Cycle	-30°C ←————→ 80°C after 5 cycle, Restore 2H at 25°C 30min 5min 30min Power off	
7	Vibration Test	10Hz~150Hz, 100m/s ² , 120min	Not allowed cosmetic and electrical defects.
8	Shock Test	Half- sine wave, 300m/s ² , 11ms	

Note: Operation: Supply 2.8V for logic system.

The inspection terms after reliability test, as below

ITEM	Inspection
Contrast	CR>50%
IDD	IDD<200%
Brightness	Brightness>60%
Color Tone	Color Tone+/-0,05

9. Precautions for Use of LCD Modules

9.1 Handling Precautions

9.1.1 The display panel is made of glass. Do not subject it to a mechanical shock by dropping it from a high place, etc.

9.1.2 If the display panel is damaged and the liquid crystal substance inside it leaks out, be sure not to get any in your mouth, if the substance comes into contact with your skin or clothes, promptly wash it off using soap and water.

9.1.3 Do not apply excessive force to the display surface or the adjoining areas since this may

IIDWay Technology Co. Ltd

cause the color tone to vary.

9.1.4 The polarizer covering the display surface of the LCD module is soft and easily scratched. Handle this polarizer carefully.

9.1.5 If the display surface is contaminated, breathe on the surface and gently wipe it with a soft dry cloth. If still not completely clear, moisten cloth with one of the following solvents:

— Isopropyl alcohol — Ethyl alcohol

Solvents other than those mentioned above may damage the polarizer. Especially, do not use the following:

— Water — Ketone — Aromatic solvents

9.1.6 Do not attempt to disassemble the LCD Module.

9.1.7 If the logic circuit power is off, do not apply the input signals.

9.1.8 To prevent destruction of the elements by static electricity, be careful to maintain an optimum work environment.

- a. Be sure to ground the body when handling the LCD Modules.
- b. Tools required for assembly, such as soldering irons, must be properly ground.
- c. To reduce the amount of static electricity generated, do not conduct assembly and other work under dry conditions.
- d. The LCD Module is coated with a film to protect the display surface. Be care when peeling off this protective film since static electricity may be generated.

9.2 Storage precautions

9.2.1 When storing the LCD modules, avoid exposure to direct sunlight or to the light of fluorescent lamps.

9.2.2 The LCD modules should be stored under the storage temperature range. If the LCD modules will be stored for a long time, the recommend condition is:

Temperature : 0°C ~ 40°C

Relatively humidity: ≤80%

9.2.3 The LCD modules should be stored in the room without acid, alkali and harmful gas.

IIDWay Technology Co. Ltd

9.3 The LCD modules should be no falling and violent shocking during transportation, and also should avoid excessive press, water, damp and sunshine.

END
