

PRODUCT SPECIFICATIONS

For Customer: _____

: APPROVAL FOR SPECIFICATION

Customer Model No. _____

: APPROVAL FOR SAMPLE

Module No.: GZ70131-DIT070WS

Date : 2019.05.20

Table of Contents

No.	Item	Page
1	Cover Sheet(Table of Contents)	P1
2	Revision Record	P2
3	General Specifications	P3
4	Outline Drawing	P4
5	Absolute Maximum Ratings	P5
6	Electrical Specifications	P6-P10
7	Optical Characteristics	P11-P14
8	Reliability Test Items and Criteria	P15
9	Precautions for Use of LCD Modules	P16-P17

For Customer's Acceptance:

Approved By	Comment

PREPARED	CHECKED	VERIFIED BY QA DEPT	VERIFIED BY R&D DEPT
YGM			

2. Revision Record

Date	Rev.No.	Page	Revision Items	Prepared
2019.05.20	V0		The first release	YGM

3. General Specifications

GZ70131-DIT070WS is a TFT-LCD module. It is composed of a TFT-LCD panel, driver IC, FPC, a back light unit. The 7.0" display area contains 1024 x (RGB) x 600 pixels and can display up to 16.7M colors. This product accords with ROHS environmental criterion.

Item	Contents	Unit	Note
LCD Type	TFT	-	
Display color	16.7M		1
Viewing Direction	ALL	O'Clock	
Operating temperature	-20~+70	°C	
Storage temperature	-30~+80	°C	
Module size	Refer to outline drawing	mm	2
Active Area(W×H)	154.21 X 85.92	mm	
Number of Dots	1024 X 600	dots	
TFT Controller	HX8282A11/HX8696A01	-	
Power Supply Voltage	3.3	V	
Outline Dimensions	Refer to outline drawing	-	2
Backlight	3S10P-LEDs (white)	pcs	
Weight	---	g	
Interface	LVDS	-	

Note

1:

Color tune is slightly changed by temperature and driving voltage.

Note 2: Without FPC and Solder.

4.Outline.Drawing

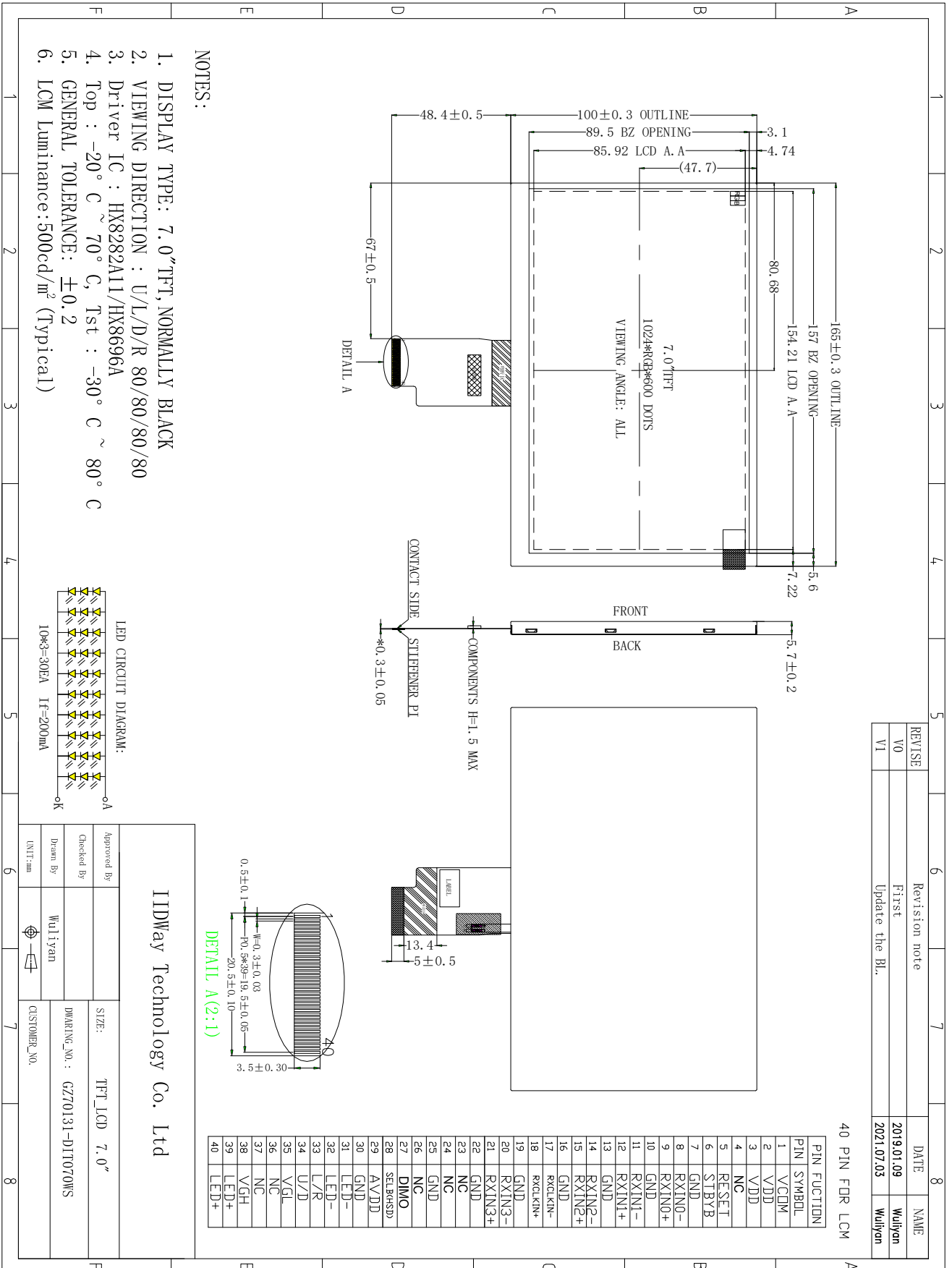

REVISE	Revision note	DATE	NAME
V0	First	2019.01.09	Wuliyan
V1	Update the Bl.	2021.07.03	Wuliyan

5. Absolute Maximum Ratings($T_a=25^\circ\text{C}$)

5.1 Electrical Absolute Maximum Ratings.($V_{SS}=0V, T_a=25^\circ\text{C}$)

Item	Symbol	Min.	Max.	Unit	Note
Power Supply Voltage	VDD	-0.50	3.96	V	1, 2
	AVDD	-0.5	14.85	V	1, 2
	VGH	-0.3	VGL+42	V	1, 2
	VGL	-25	0.3	V	1, 2

Notes:

- If the module is above these absolute maximum ratings. It may become permanently damaged. Using the module within the following electrical characteristic conditions are also exceeded, the module will malfunction and cause poor reliability.
- $V_{DD} > V_{SS}$ must be maintained.
- Please be sure users are grounded when handing LCD Module.

5.2 Environmental Absolute Maximum Ratings.

Item	Storage		Operating		Note
	MIN.	MAX.	MIN.	MAX.	
Ambient Temperature	-30°C	80°C	-20°C	70°C	1,2
Humidity	-	-	-	-	3

- The response time will become lower when operated at low temperature.
- Background color changes slightly depending on ambient temperature.
The phenomenon is reversible.
- $T_a \leq 40^\circ\text{C}$:85%RH MAX.

$T_a > 40^\circ\text{C}$:Absolute humidity must be lower than the humidity of 85%RH at 40°C .

6. Electrical Specifications and Instruction Code

6.1 Electrical characteristics for LCD($V_{SS}=0V, T_a=25^\circ C$)

Parameter	Symbol	Condition	Min	Typ	Max	Unit	Note
Power supply	VDD	$T_a=25^\circ C$	3.0	3.3	3.6	V	
Power supply	VGH	$T_a=25^\circ C$	17	18	19	V	
Power supply	VGL	$T_a=25^\circ C$	-7	-6	-5	V	
Power supply	AVDD	$T_a=25^\circ C$	9.3	9.6	9.9	V	
Power supply	VCOM	$T_a=25^\circ C$	3.35	3.65	3.95	V	
Input voltage	'H'	V_{IH}	$V_{DD}=3.3V$	$0.7V_{DD}$	-	V_{DD}	V
	'L'	V_{IL}	$V_{DD}=3.3V$	0	-	$0.3V_{DD}$	V

6.2 LED backlight specification($V_{SS}=0V, T_a=25^\circ C$)

Item	Symbol	Condition	Min	Typ	Max	Unit	Note
Supply voltage	V_f	$I_f=200mA$	8.1	9.0	9.9	V	
Uniformity	ΔB_p	$I_f=200mA$	75	80	-	%	
Life Time	time	$I_f=200mA$	-	30K		hours	1

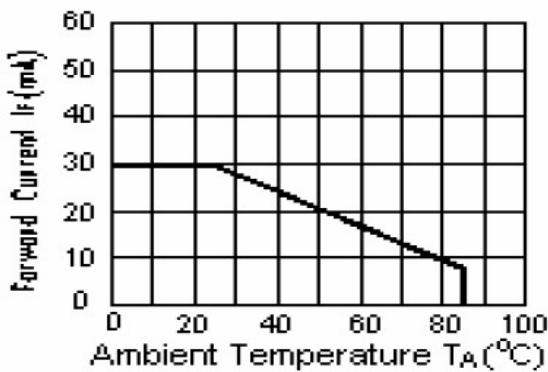

ILED VS TEMP

6.3 Interface signals

Pin No.	Symbol	I/O	Function	
1	VCOM	P	Common voltage	
2-3	VDD	P	Power supply	
4	NC	-	No connection.	
5	RESET	I	Reset pin, normally pull high	
6	STBYB	I	Standby mode control pin, normally pull high	
7	GND	P	Ground.	
8	RXIN0-	I	LVDS lane0 input	
9	RXIN0+	I		
10	GND	P	Ground.	
11	RXIN1-	I	LVDS lane1 input	
12	RXIN1+	I		
13	GND	P	Ground.	
14	RXIN2-	I	LVDS lane2 input	
15	RXIN2+	I		
16	GND	P	Ground.	
17	RXCLKIN-	I	LVDS CLK input	
18	RXCLKIN+	I		
19	GND	P	Ground.	
20	RXIN3-	I	LVDS lane3 input	
21	RXIN3+	I		
22	GND	P	Ground.	
23-24	NC	-	No connection.	
25	GND	P	Ground.	
26	NC	-	No connection.	
27	DIMO	O	No connection.	
28	SELB	I	SELB=0	LVDS 8 BIT
			SELB=1	LVDS 6BIT
29	AVDD	-	Power for analog circuit	
30	GND	P	Ground.	
31-32	LED-	P	LED Ground	
33	L/R	I	Source Right or Left sequence control.	
34	U/D	I	Gate Up or Down scan control.	
35	VGL	P	Gate off voltage	
36-37	NC	-	No connection.	
38	VGH	P	Gate on voltage	
39-40	LED+	P	LED Power	

6.4 AC Characteristics

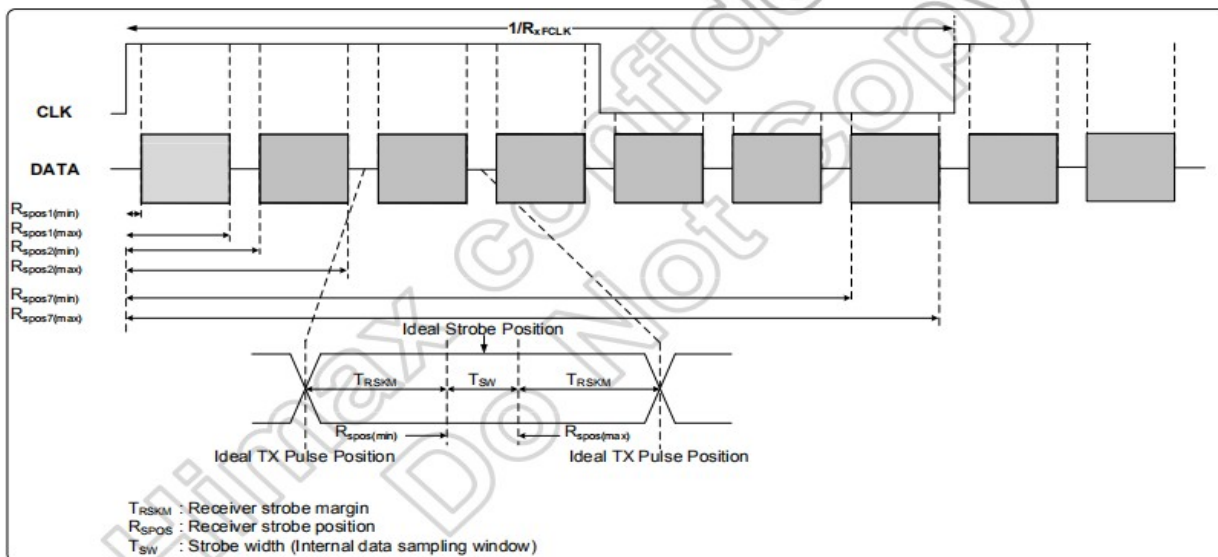
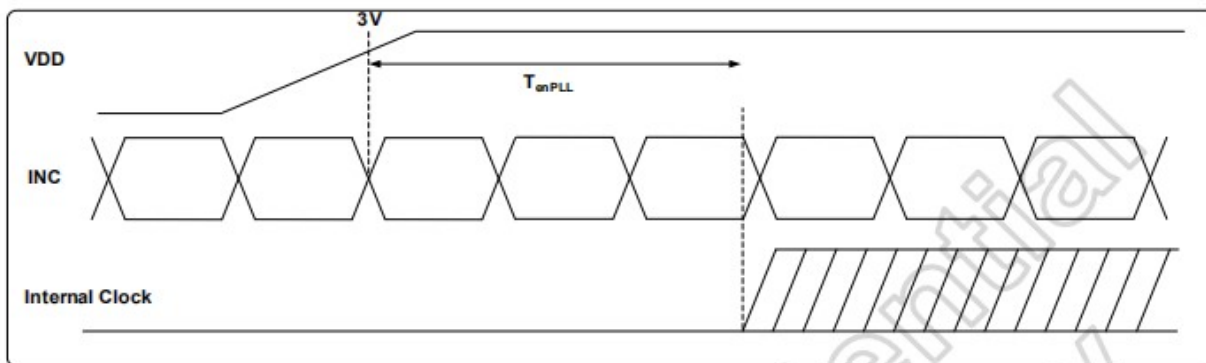
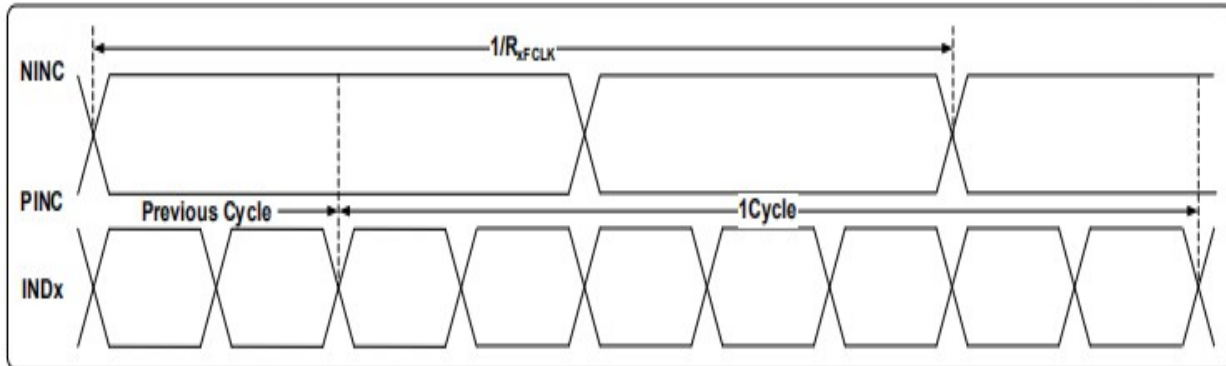

6.5 Data input format

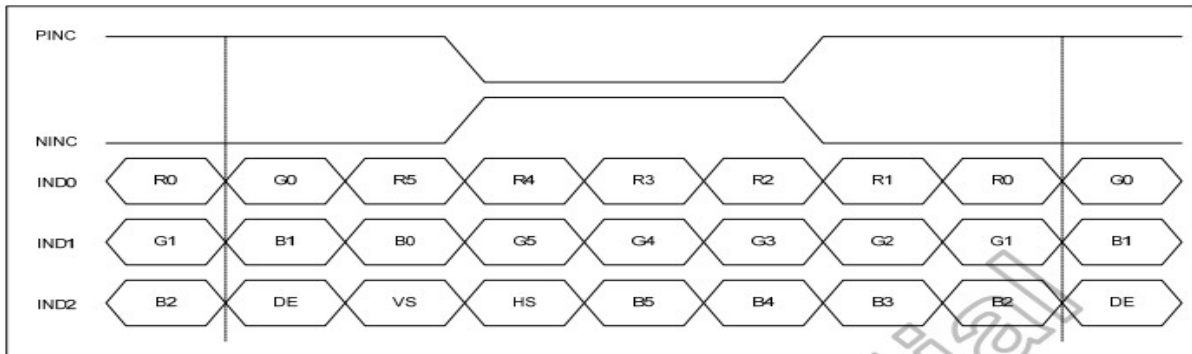

6-bit LVDS input

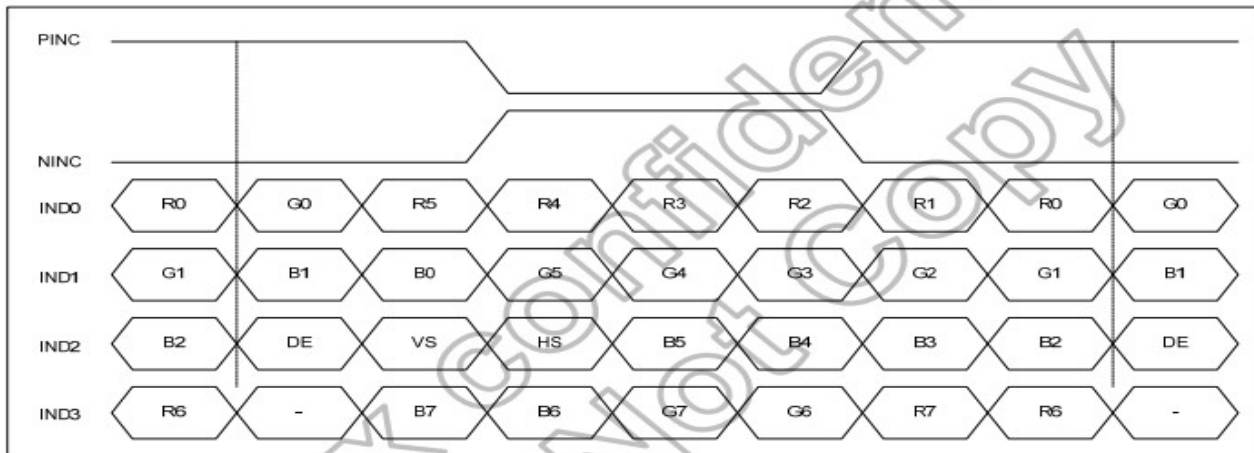

8-bit LVDS input

6.6 Input timing table

DE mode

Parameter	Symbol	Spec.			Unit
		Min.	Typ.	Max.	
DCLK frequency	fclk	40.8	51.2	67.2	MHz
Horizontal display area	thd	1024			DCLK
HSD period	th	1114	1344	1400	DCLK
HSD blanking	thb+thfp	90	320	376	DCLK
Vertical display area	tvd	600			T _H
VSD period	tv	610	635	800	T _H
VSD blanking	tvbp+tvfp	10	35	200	T _H

HV mode

• Horizontal timing

Parameter	Symbol	Spec.			Unit
		Min.	Typ.	Max.	
DCLK frequency	fclk	44.9	51.2	63	MHz
Horizontal display area	thd	1024			DCLK
HSD period	th	1200	1344	1400	DCLK
HSD pulse Width	thpw	1	-	140	DCLK
HSD back porch	thbp	160			DCLK
HSD front porch	thfp	16	160	216	DCLK

• Vertical timing

Parameter	Symbol	Spec.			Unit
		Min.	Typ.	Max.	
Vertical display area	tvd	600			T _H
VSD period	tv	624	635	750	T _H
VSD pulse width	tvpw	1	-	20	T _H
VSD back porch	tvbp	23			T _H
VSD front porch	tvfp	1	12	127	T _H

7. Optical Characteristics

Item	Symbol	Condition	Min.	Typ.	Max.	Unit	Note	
Brightness	Bp	$\theta=0^\circ$	-	500	-	Cd/m ²	1	
Uniformity	$\triangle Bp$	$\Phi=0^\circ$	75	80	-	%	1,2	
Viewing Angle	3:00	Cr \geq 10	-	80	-	Deg	3	
	6:00		-	80	-			
	9:00		-	80	-			
	12:00		-	80	-			
Contrast Ratio	Cr	Ta=25°C $\Phi=0^\circ$	500	800	-	-	4	
Response Time	Tr+Tf		-	25	40	ms	5	
Color of CIE Coordinate	W	x	$\theta=0^\circ$ $\Phi=0^\circ$	TYP- 0.05	TBD	TYP+0 .05	-	1,6
		y			TBD		-	
	R	x			TBD		-	
		y			TBD		-	
	G	x			TBD		-	
		y			TBD		-	
	B	x			TBD		-	
		y			TBD		-	
NTSC Ratio	S	45	50	-	%			

Note: The parameter is slightly changed by temperature, driving voltage and materiel

IIDWAY Technology Co. Ltd

Note 1: The data are measured after LEDs are turned on for 5 minutes. LCM displays full white. The brightness is the average value of 9 measured spots. Measurement equipment BM-7 (Φ5mm)

Measuring condition:

- Measuring surroundings: Dark room.
- Measuring temperature: $T_a=25\text{ }^\circ\text{C}$.
- Adjust operating voltage to get optimum contrast at the center of the display.

Measured value at the center point of LCD panel after more than 5 minutes while backlight turning on.

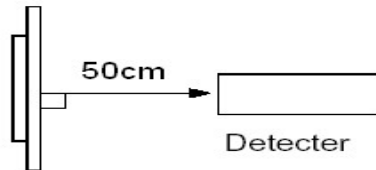

Note 2: The luminance uniformity is calculated by using following formula.

$$\Delta Bp = Bp (\text{Min.}) / Bp (\text{Max.}) \times 100 (\%)$$

$Bp (\text{Max.})$ = Maximum brightness in 9 measured spots

$Bp (\text{Min.})$ = Minimum brightness in 9 measured spots.

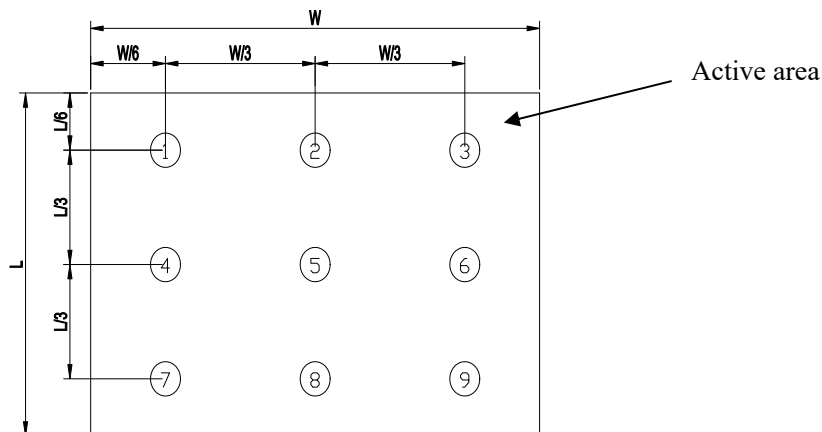

Note 3: The definition of viewing angle:

Refer to the graph below marked by ϑ and ϕ

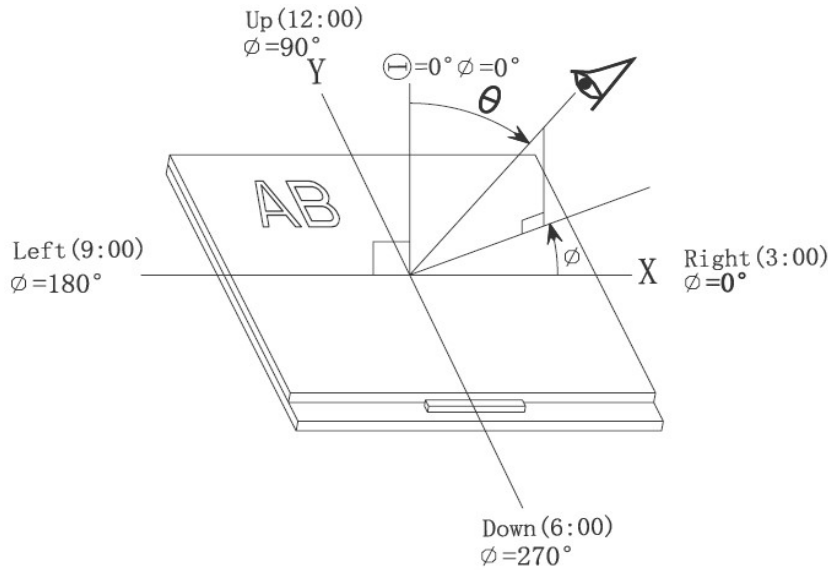

Note 4: Definition of contrast ratio.(Test LCD using DMS501)

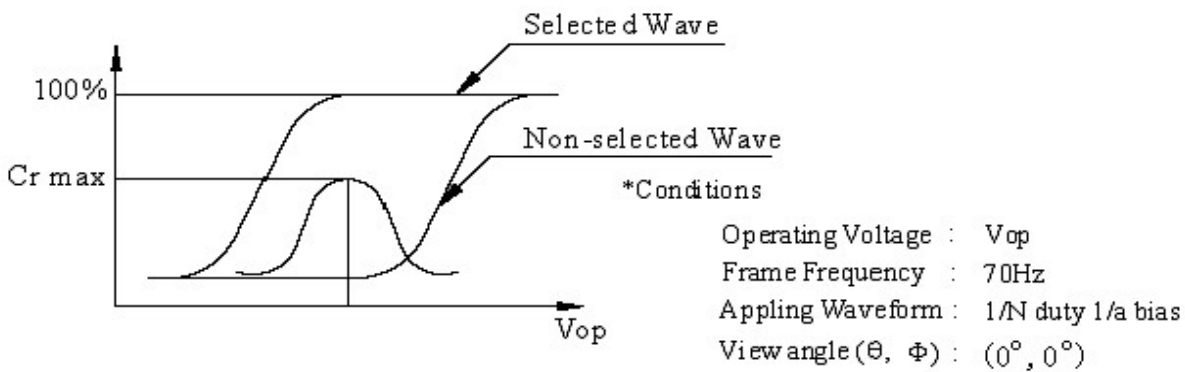

$$\text{Contrast ratio}(Cr) = \frac{\text{Brightness of selected dots}}{\text{Brightness of non-selected dots}}$$

Note 5: Definition of Response time. (Test LCD using DMS501):

The output signals of photo detector are measured when the input signals are changed from "black" to "white" (falling time) and from "white" to "black" (rising time), respectively. The response time is defined as the time interval between the 10% and 90% of amplitudes. Refer to figure as below.

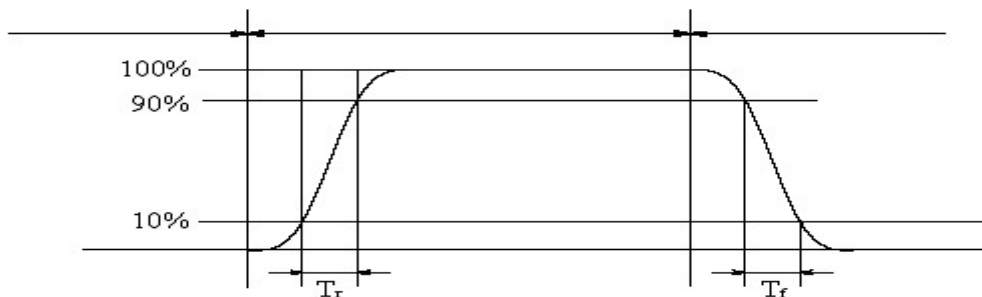

The definition of response time

Note 6: Definition of Color of CIE Coordinate and NTSC Ratio.

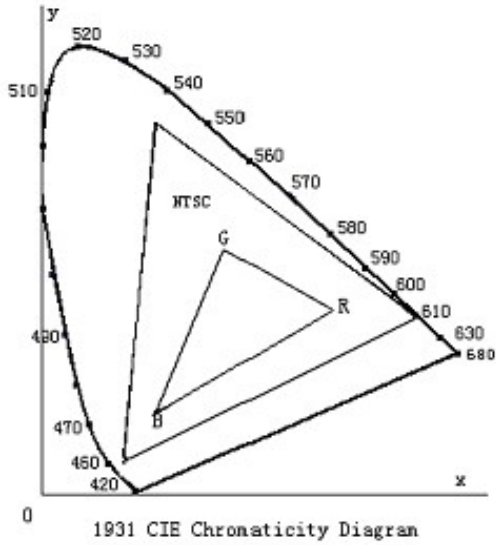

Color gamut:

$$S = \frac{\text{area of RGB triangle}}{\text{area of NTSC triangle}} \times 100\%$$

Note 7: Definition of cross talk.

$$\text{Cross talk ratio(\%)} = \frac{|\text{pattern A Brightness} - \text{pattern B Brightness}|}{\text{pattern A Brightness}} \times 100$$

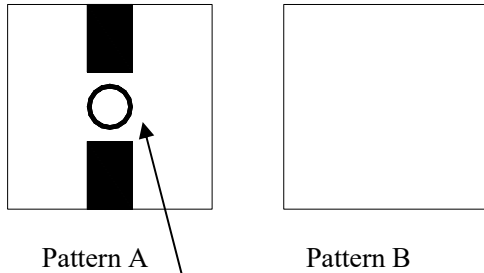

Measurement point(center)

Electric volume value=3F+/-3Hex

8. Reliability Test Items and Criteria

No	Test Item	Test condition	Criterion
1	High Temperature Storage	80°C±2°C 96H Restore 2H at 25°C Power off	1. After testing, cosmetic and electrical defects should not happen. 2. Total current consumption should not be more than twice of initial value.
2	Low Temperature Storage	-30°C±2°C 96H Restore 2H at 25°C Power off	
3	High Temperature Operation	70°C±2°C 96H Restore 2H at 25°C Power on	
4	Low Temperature Operation	-20°C±2°C 96H Restore 4H at 25°C Power on	
5	High Temperature/Humidity Operation	60°C±2°C 90%RH 96H Power on	
6	Temperature Cycle	-30°C —————> 80°C 30min 5min 30min after 5 cycle, Restore 2H at 25°C Power off	

Note: Operation: Supply 3.3V for logic system.

The inspection terms after reliability test, as below

ITEM	Inspection
Contrast	CR>50%
IDD	IDD<200%
Brightness	Brightness>60%
Color Tone	Color Tone+/-0,05

9. Precautions for Use of LCD Modules

9.1 Handling Precautions

9.1.1 *The display panel is made of glass. Do not subject it to a mechanical shock by dropping it from a high place, etc.*

9.1.2 *If the display panel is damaged and the liquid crystal substance inside it leaks out, be sure not to get any in your mouth, if the substance comes into contact with your skin or clothes, promptly wash it off using soap and water.*

9.1.3 *Do not apply excessive force to the display surface or the adjoining areas since this may cause*

the color tone to vary.

9.1.4 The polarizer covering the display surface of the LCD module is soft and easily scratched. Handle this polarizer carefully.

9.1.5 If the display surface is contaminated, breathe on the surface and gently wipe it with a soft dry cloth. If still not completely clear, moisten cloth with one of the following solvents:

— Isopropyl alcohol — Ethyl alcohol

Solvents other than those mentioned above may damage the polarizer. Especially, do not use the following:

— Water — Ketone — Aromatic solvents

9.1.6 Do not attempt to disassemble the LCD Module.

9.1.7 If the logic circuit power is off, do not apply the input signals.

9.1.8 To prevent destruction of the elements by static electricity, be careful to maintain an optimum work environment.

a. Be sure to ground the body when handling the LCD Modules.

b. Tools required for assembly, such as soldering irons, must be properly ground.

c. To reduce the amount of static electricity generated, do not conduct assembly and other work under dry conditions.

d. The LCD Module is coated with a film to protect the display surface. Be care when peeling off this protective film since static electricity may be generated.

9.2 Storage precautions

9.2.1 When storing the LCD modules, avoid exposure to direct sunlight or to the light of fluorescent lamps.

9.2.2 The LCD modules should be stored under the storage temperature range. If the LCD modules will be stored for a long time, the recommend condition is:

Temperature : 0°C ~ 40°C

Relatively humidity: ≤80%

9.2.3 The LCD modules should be stored in the room without acid, alkali and harmful gas.

9.3 The LCD modules should be no falling and violent shocking during transportation, and also should avoid excessive press, water, damp and sunshine.

END