

IIDWay Technology Co. Ltd

PRODUCT SPECIFICATIONS

For Customer: _____

: APPROVAL FOR SPECIFICATION

Customer Model No. _____

: APPROVAL FOR SAMPLE

Module No.: GZ70106-DIT104XG

Date : 2024.2.23

Table of Contents

No.	Item	Page
1	Cover Sheet(Table of Contents)	P1
2	Revision Record	P2
3	General Specifications	P3
4	Outline Drawing	P4
5	Absolute Maximum Ratings	P5
6	Electrical Specifications	P6-P13
7	Optical Characteristics	P14-P17
8	Reliability Test Items and Criteria	P18
9	Precautions for Use of LCD Modules	P19-P20

For Customer's Acceptance:

Approved By	Comment

PREPARED	CHECKED	APPROVER
YZJ		

IIDWay Technology Co. Ltd

3. General Specifications

GZ70106-DIT104XG is a TFT-LCD module. It is composed of a TFT-LCD panel, driver IC, FPC, a back light unit. The 10.4" display area contains 1024x768 pixels and can display up to 16.7M colors. This product accords with RoHS environmental criterion.

Item	Contents	Unit	Note
LCD Type	TFT	-	
Display color	16.7M	1	
Viewing Direction	ALL	O'Clock	
Operating temperature	-20~+70	°C	
Storage temperature	-30~+80	°C	
Module size	Refer to outline drawing	mm	
Active Area(W×H)	210.43X157.82	mm	
Number of Dots	1024x768	dots	
Driver IC	-	-	
Power Supply Voltage	3.3	V	
Backlight	13S2P-LEDs (white)	pcs	
Interface	LVDS	-	

Note1: Color tune is slightly changed by temperature and driving voltage.

IIDWay Technology Co. Ltd

4.Outline.Drawing

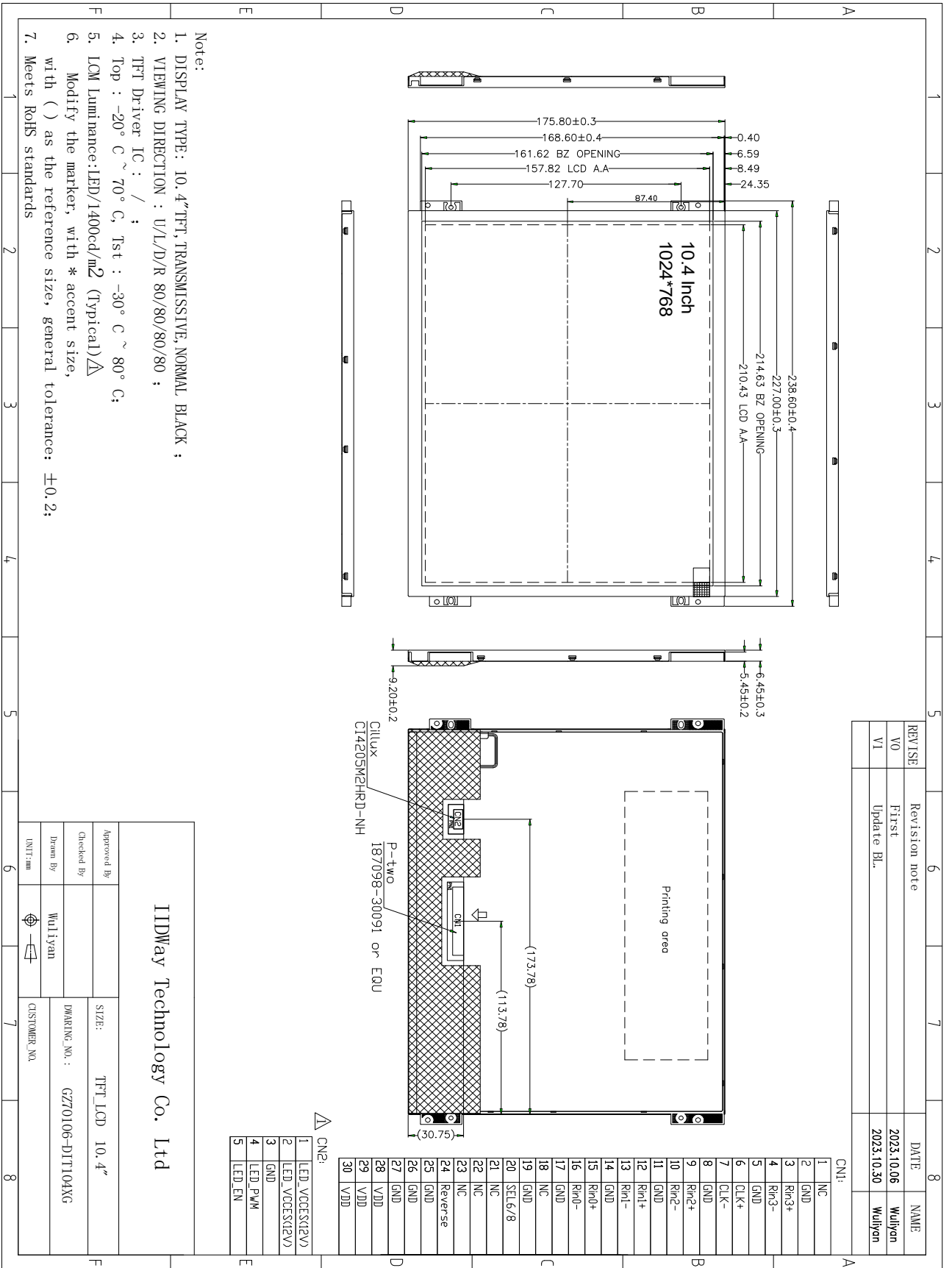

IIDWay Technology Co. Ltd

5. Absolute Maximum Ratings($T_a=25^\circ\text{C}$)

5.1 Electrical Absolute Maximum Ratings.($V_{SS}=0\text{V}$, $T_a=25^\circ\text{C}$)

Item	Symbol	Min.	Max.	Unit	Note
Power Supply Voltage	V_{DD}	-0.3	3.8	V	1, 2

Notes:

1. If the module is above these absolute maximum ratings. It may become permanently damaged. Using the module within the following electrical characteristic conditions are also exceeded, the module will malfunction and cause poor reliability.
2. $V_{DD} > V_{SS}$ must be maintained.
3. Please be sure users are grounded when handing LCD Module.

5.2 Environmental Absolute Maximum Ratings.

Item	Storage		Operating	
	MIN.	MAX.	MIN.	MAX.
Ambient Temperature	-30°C	80°C	-20°C	70°C
Humidity	-	-	-	-

1. The response time will become lower when operated at low temperature.
2. Background color changes slightly depending on ambient temperature.

The phenomenon is reversible.

3. $T_a \leq 40^\circ\text{C}$: 85%RH MAX.

$T_a > 40^\circ\text{C}$: Absolute humidity must be lower than the humidity of 85%RH at 40°C .

IIDWay Technology Co. Ltd

6. Electrical Specifications and Instruction Code

6.1 Electrical characteristics($V_{SS}=0V, T_a=25^\circ C$)

Parameter	Symbol	Condition	Min	Typ	Max	Unit	Note
Power supply	VDD	$T_a=25^\circ C$	3.0	3.3	3.6	V	
Input voltage	'H'	V_{IH}	$V_{DD}=3.3V$	$0.7V_{DD}$	-	V_{DD}	V
	'L'	V_{IL}	$V_{DD}=3.3V$	0	-	$0.3V_{DD}$	V

Note: If one of the above items is exceeded its maximum limitation momentarily, the quality of the product may be degraded. Absolute maximum limitation, therefore, specify the values exceeding which the product may be physically damaged. Be sure to use the product within the recommend range.

6.2 LED backlight specification($V_{SS}=0V, T_a=25^\circ C$)

Item	Symbol	Condition	Min	Typ	Max	Unit	Note
Supply voltage VLED	V_f	$I_f=240mA$	35.1	39	42.9	V	
Uniformity	ΔB_p	$I_f=240mA$	70	-	-	%	
LED Life Time	-	-	30K	-	-	hr	1

Note 1: Brightness to be decreased to 50% of the initial value at ambient temperature $T_A=25^\circ C$

IIDWay Technology Co. Ltd

6.3 Interface signals

CN1

Pin No.	Symbol	I/O	Function
1	NC		No Connection
2	GND	P	Ground
3	Rin3+	I	Positive LVDS differential data pair1
4	Rin3-	I	Negative LVDS differential data pair1
5	GND	P	Ground
6	CLK+	I	Positive LVDS differential clock pair
7	CLK-	I	Negative LVDS differential clock pair
8	GND	P	Ground
9	Rin2+	I	Positive LVDS differential data pair1
10	Rin2-	I	Negative LVDS differential data pair1
11	GND	P	Ground
12	Rin1+	I	Positive LVDS differential data pair1
13	Rin1-	I	Negative LVDS differential data pair1
14	GND	P	Ground
15	Rin0+	I	Positive LVDS differential data pair1
16	Rin0-	I	Negative LVDS differential data pair1
17	GND	P	Ground
18	NC		No Connection
19	GND	P	Ground
20	SELB6/8	I	Selection for 6 bits/8bit LVDS data input Low or NC : 8 bit input mode High : 6 bit input mode
21-23	NC		No Connection
24	Reverse	I	Reverse panel function (Display rotation)
25-27	GND	P	Ground
28-30	VDD	P	Analog or digital supply voltage

IIDWay Technology Co. Ltd

Connector 2: Cillux,CI4205M2HRD-NH

5-pin connector is used for input power & control signals for BL converter power IC

No	Symbol	I/O	Function	Remark
1	LED_VCCS	P	12V input	
2	LED_VCCS	P	12V input	
3	GND	P	Ground	
4	LED_PWM	I	PWM	
5	LED_EN	I	Converter power IC Enable (Active High)	

IIDWay Technology Co. Ltd

6.4 Power Sequence

The power sequence specifications are shown as the following table and diagram.

Symbol	Value		Unit
	Min.	Max.	
t_1	1	20	ms
t_2	1	5	ms
t_3	10	50	ms
t_4	200	500	ms
t_5	200	500	ms
t_6	50	200	ms
t_7	0	20	ms
t_8	500	-	ms
t_A	0	50	ms
t_B	0	50	ms

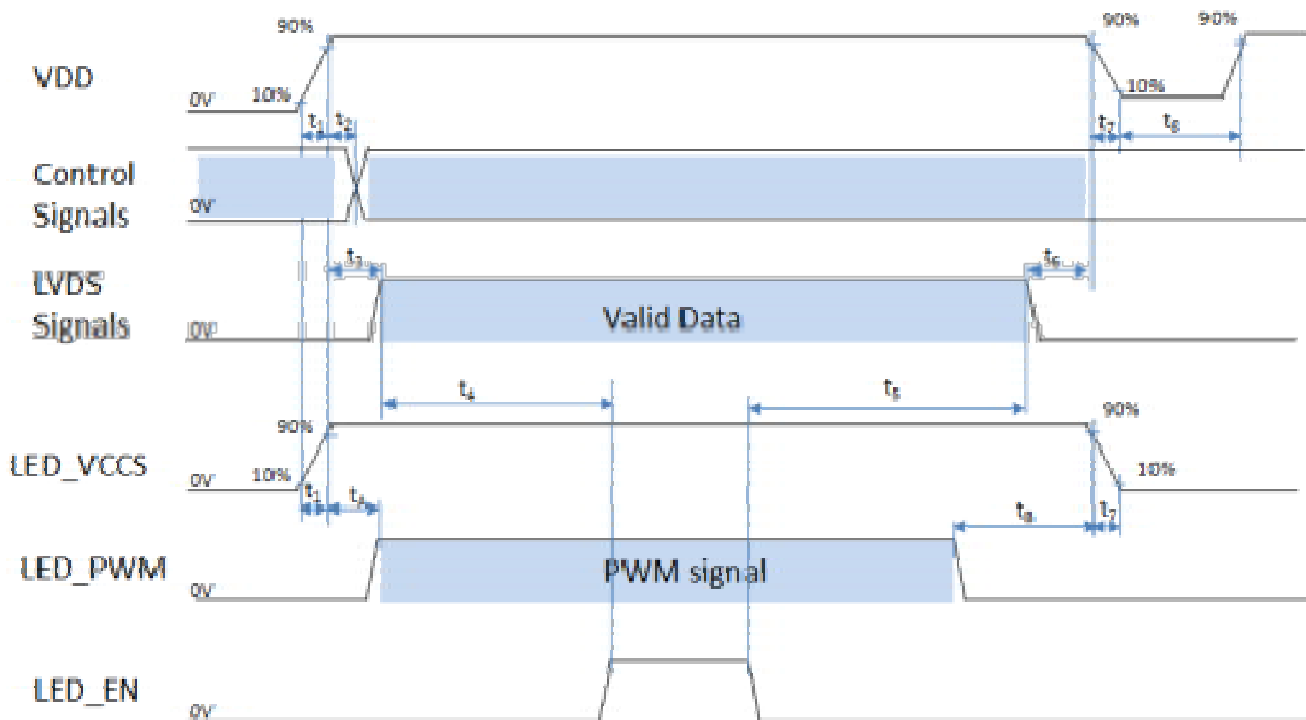

Note 1: Please don't plug the interface cable of on when system is turned on.

Note 2: Please avoid floating state of the interface signal during signal invalid period.

Note 3: It is recommended that the backlight power must be turned on after the power supply for LCD and the interface signal is valid.

Note 4: Control signals include SEL6/8 & Reverse.

IIDWay Technology Co. Ltd

6.5 Timing Characteristics

6.5.1 AC Electrical Characteristics

Parameter	Symbol	Min	Typ	Max	Units	Condition
Clock frequency	RxFCLK	26.2	51.2	71	MHz	
Input data skew margin	TRSKM	500	500	$1/(2 \cdot RxFCLK)$	ps	Typical value for 1024*600 resolution
Clock high time	TLVCH		$4/(7 \cdot RxFCLK)$		ns	VID =400mv RxVCM=1.2V RxFCLK=71MHz VDD_LVDS=3.3V
Clock low time	TLVCL		$3/(7 \cdot RxFCLK)$		ns	
VSD setup time	TenPLL	0	TenPLL	150	us	

6.5.2 Input clock and data timing diagram

IIDWay Technology Co. Ltd

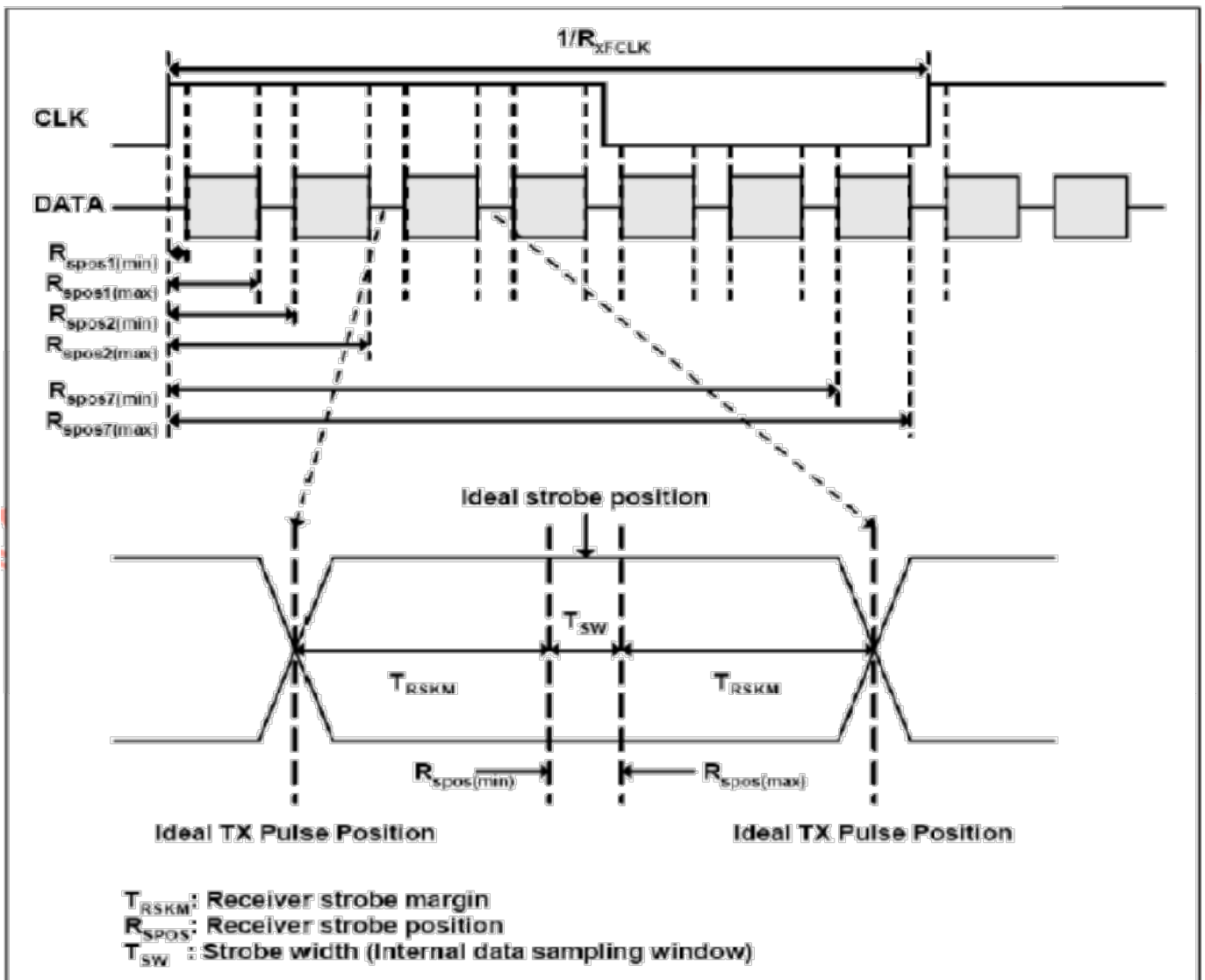
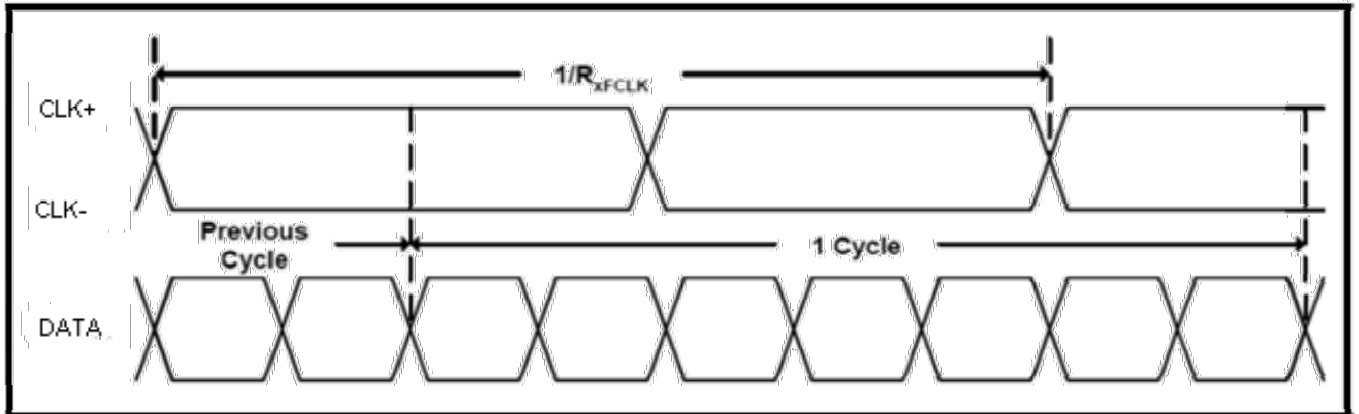

6.5.3 DC electrical characteristics

IIDWay Technology Co. Ltd

Parameter	Symbol	Values			Unit	Remark
		Min.	Typ.	Max.		
LVDS Differential input high Threshold voltage	R_{xVTH}	-	-	+100	mV	$R_{xVCM}=1.2V$
LVDS Differential input low Threshold voltage	R_{xVTL}	-100	-	-	mV	
Input Voltage range (Singed-end)	R_{xVIN}	0	-	$VDD-1.2+ V_{ID} /2$	V	
LVDS Differential input common mode voltage	R_{xVCM}	$ V_{ID} /2$	-	$VDD-1.2$	V	
LVDS Differential voltage	$ V_{ID} $	0.2	-	0.6	V	

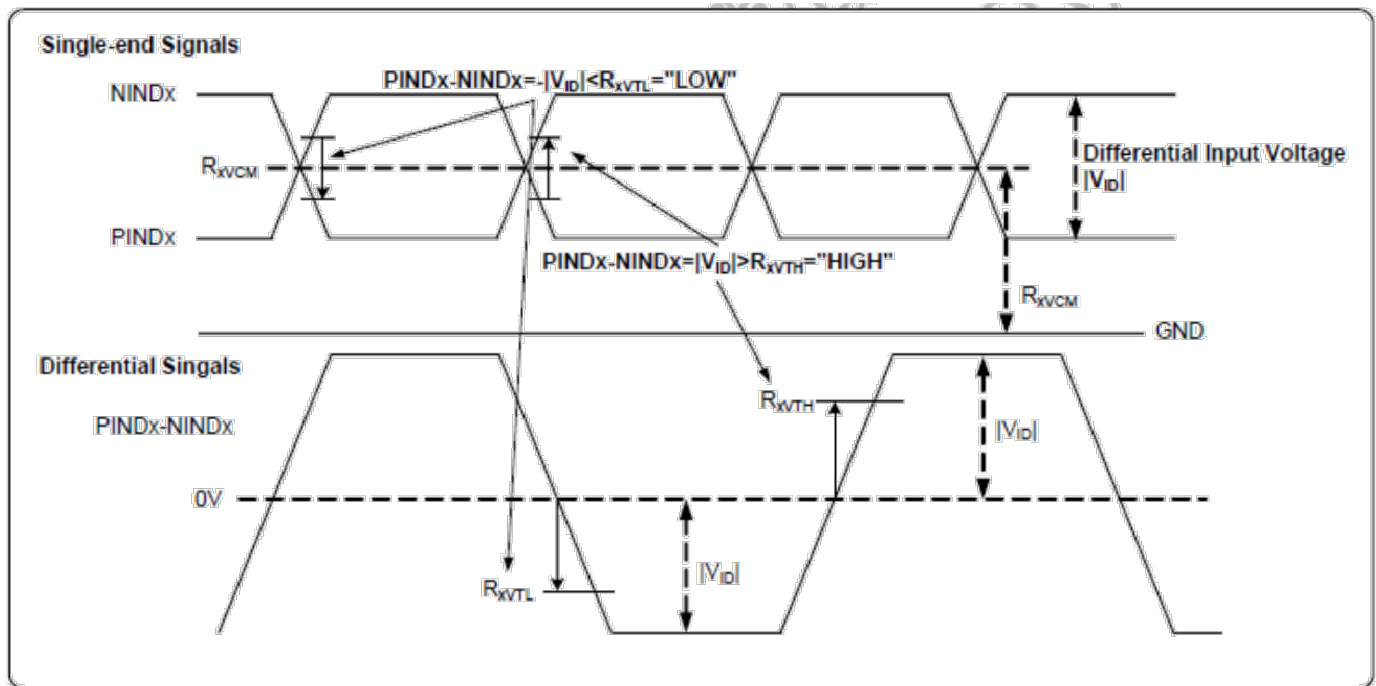

6.5.4 Data Timing

Parameter	Symbol	Spec.			Unit
		Min.	Typ.	Max.	
DCLK frequency	fclk	52	65	71	MHz
Horizontal display area	thd	1024			DCLK
HSD period	th	1114	1344	1400	DCLK
HSD blanking	thb+thfp	90	320	376	DCLK
Vertical display area	tvd	768			T_H
VSD period	tv	778	806	845	T_H
VSD blanking	tvbp+tvfp	10	38	77	T_H

6.5.5 LVDS data input format

IIDWay Technology Co. Ltd

SEL6/8 = "High" for 6 bits LVDS Input

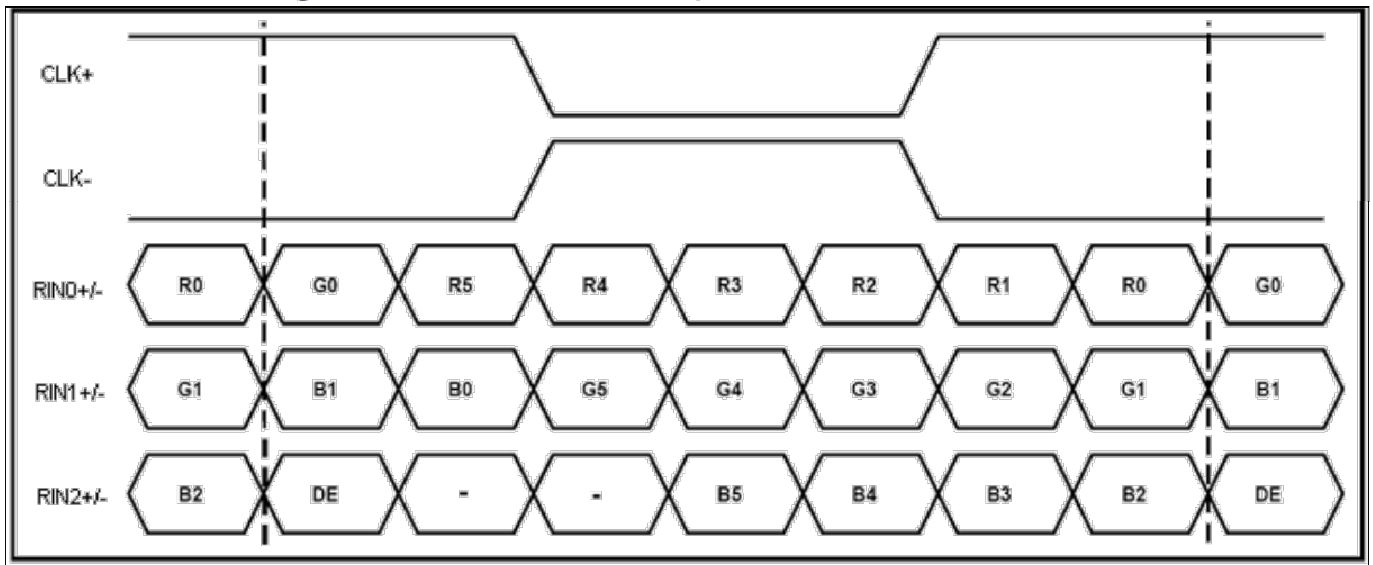

SEL6/8 = "Low" or "NC" for 8 bits LVDS Input

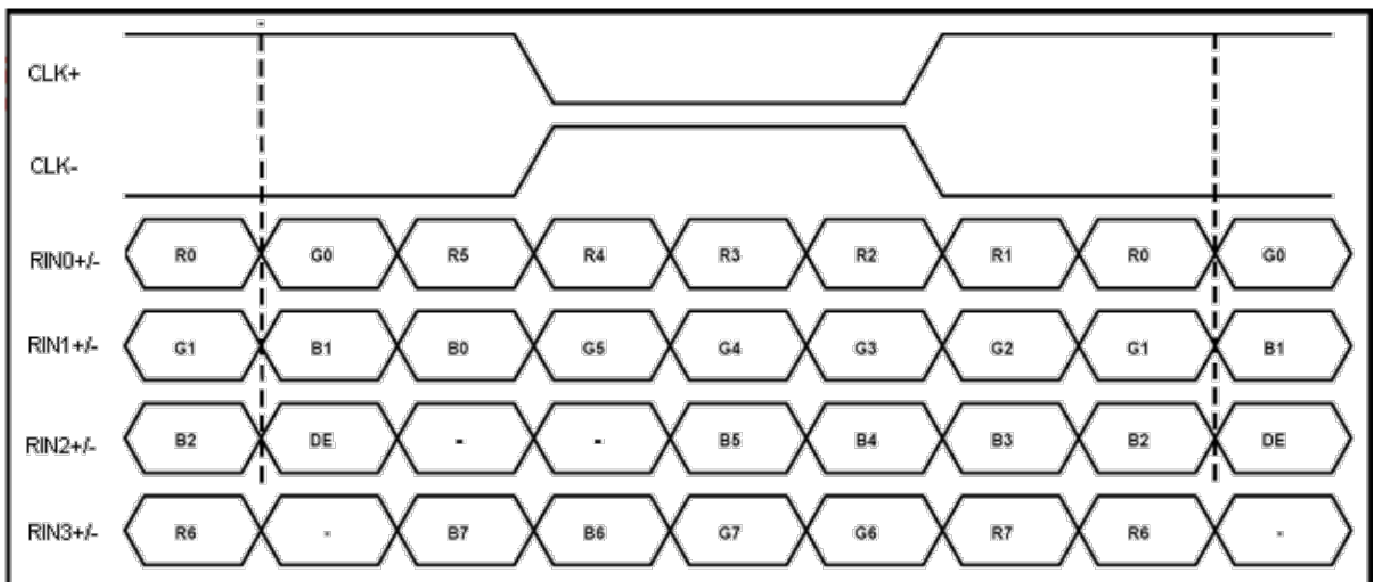

IIDWay Technology Co. Ltd

7. Optical Characteristics

Item	Symbol	Condition	Min.	Typ.	Max.	Unit	Note	
Brightness	Bp	$\theta=0^\circ$	-	1400	-	Cd/m ²	1	
Uniformity	Δ Bp	$\Phi=0^\circ$	70	-	-	%	1,2	
Viewing Angle	3:00	Cr \geq 10	-	80	-	Deg	3	
	6:00		-	80	-			
	9:00		-	80	-			
	12:00		-	80	-			
Contrast Ratio	Cr	$\theta=0^\circ$	800	1000	-	-	4	
Response Time	T _r +T _f	$\Phi=0^\circ$	-	25	35	ms	5	
Color of CIE Coordinate	W	x	$\theta=0^\circ$	Typ-0 .05	TBD	Typ+0. 05	-	1,6
		y					-	
	R	x					-	
		y					-	
	G	x					-	
		y					-	
	B	x					-	
		y					-	
NTSC Ratio	S		55	61.2	-	%		

Note: The parameter is slightly changed by temperature, driving voltage and materiel

Note 1: The data are measured after LEDs are turned on for 5 minutes. LCM displays full white. The brightness is the average value of 9 measured spots. Measurement equipment BM-7 (Φ 5mm)

Measuring condition:

- *Measuring surroundings: Dark room.*
- *Measuring temperature: Ta=25 °C.*
- *Adjust operating voltage to get optimum contrast at the center of the display.*

Measured value at the center point of LCD panel after more than 5 minutes while backlight

IIDWay Technology Co. Ltd

turning on.

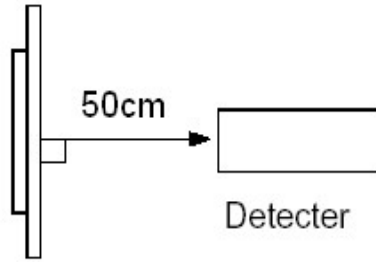

Note 2: The luminance uniformity is calculated by using following formula.

$$\Delta Bp = Bp (\text{Min.}) / Bp (\text{Max.}) \times 100 (\%)$$

$Bp (\text{Max.})$ = Maximum brightness in 9 measured spots

$Bp (\text{Min.})$ = Minimum brightness in 9 measured spots.

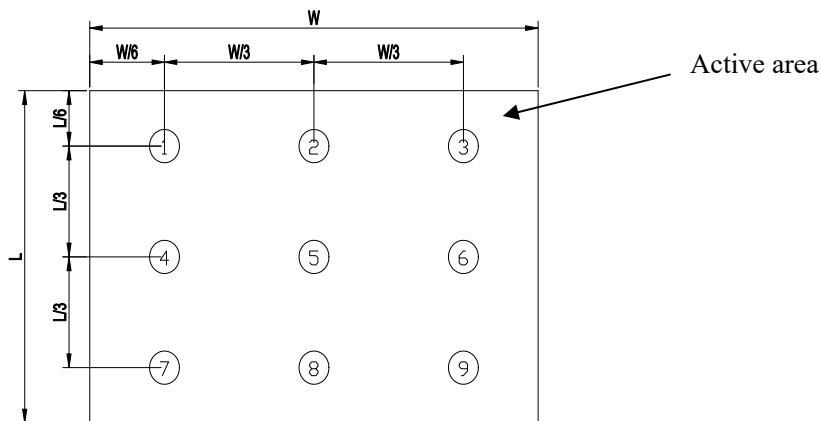

Note 3: The definition of viewing angle:

Refer to the graph below marked by ϑ and Φ

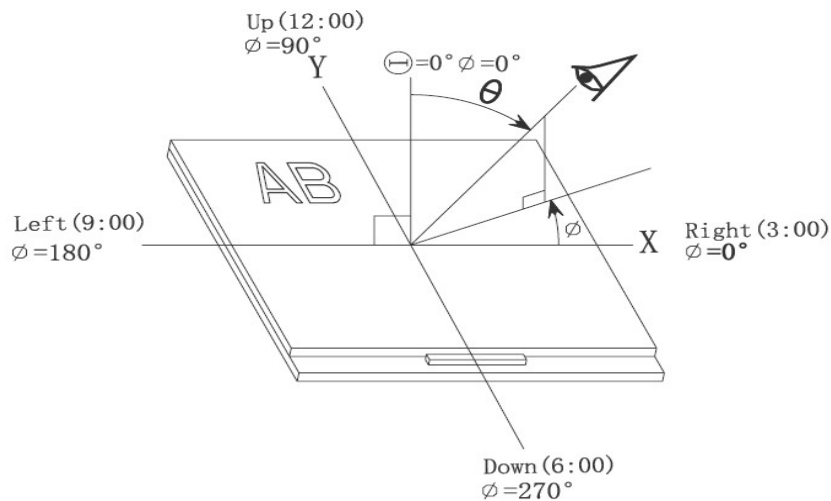

Note 4: Definition of contrast ratio.(Test LCD using DMS501)

IIDWay Technology Co. Ltd

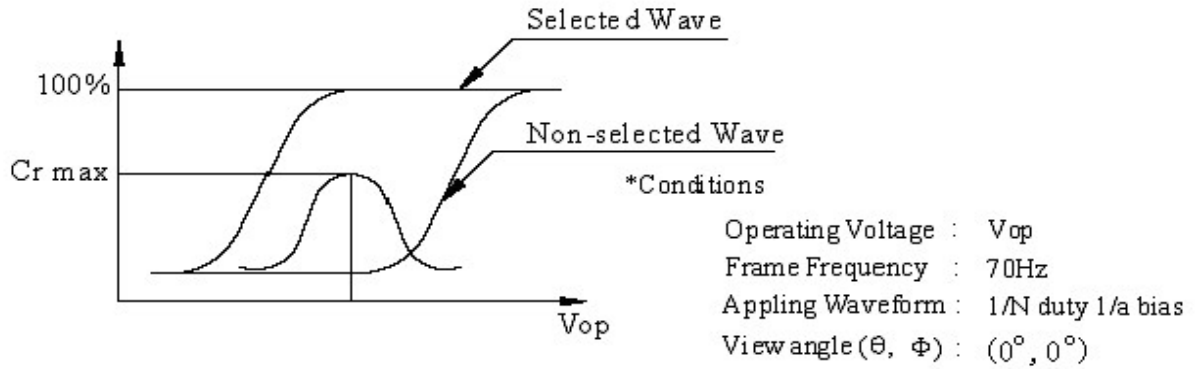

$$\text{Contrast ratio}(Cr) = \frac{\text{Brightness of selected dots}}{\text{Brightness of non-selected dots}}$$

Note 5: Definition of Response time. (Test LCD using DMS501):

The output signals of photo detector are measured when the input signals are changed from "black" to "white"(falling time) and from "white" to "black"(rising time), respectively. The response time is defined as the time interval between the 10% and 90% of amplitudes. Refer to figure as below.

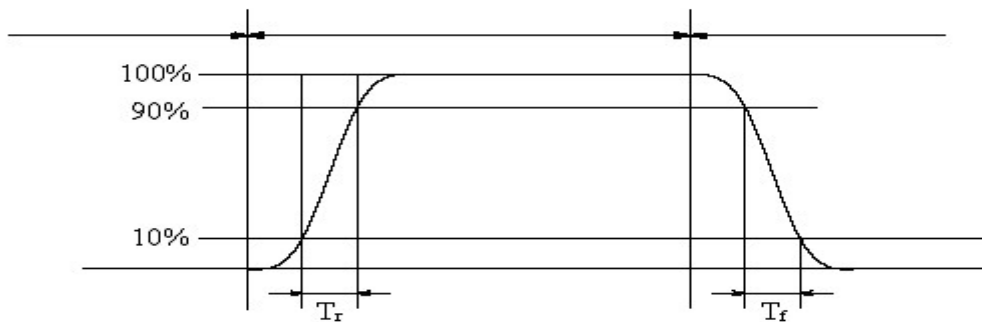

The definition of response time

Note 6: Definition of Color of CIE Coordinate and NTSC Ratio.

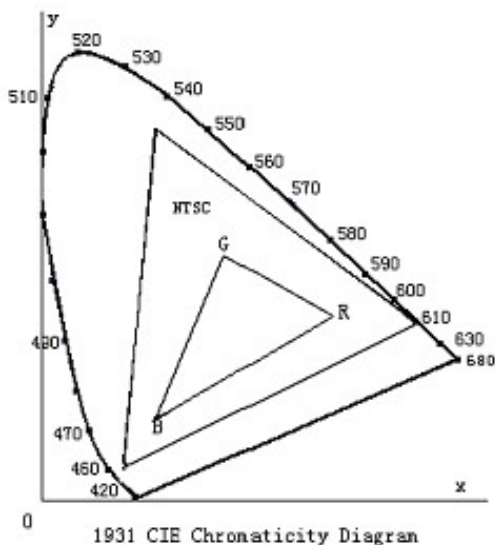

Color gamut:

$$S = \frac{\text{area of RGB triangle}}{\text{area of NTSC triangle}} \times 100\%$$

Note 7: Definition of cross talk.

IIDWay Technology Co. Ltd

*Cross talk ratio(%)=|pattern A Brightness-pattern B Brightness|/pattern A Brightness*100*

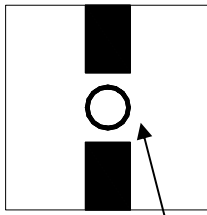

Pattern A



Pattern B

Measurement point(center)

Electric volume value=3F+/-3Hex

IIDWay Technology Co. Ltd

8. Reliability Test Items and Criteria

No	Test Item	Test condition	Criterion
1	High Temperature Storage	80°C±2°C 96H Restore 2H at 25°C Power off	1. After testing, cosmetic and electrical defects should not happen. 2. Total current consumption should not be more than twice of initial value.
2	Low Temperature Storage	-30°C±2°C 96H Restore 2H at 25°C Power off	
3	High Temperature Operation	70°C±2°C 96H Restore 2H at 25°C Power on	
4	Low Temperature Operation	-20°C±2°C 96H Restore 4H at 25°C Power on	
5	High Temperature/Humidity Operation	60°C±2°C 90%RH 96H Power on	
6	Temperature Cycle	-30°C → 80°C 30min 5min 30min after 5 cycle, Restore 2H at 25°C Power off	

Note: Operation: Supply 3.3V for logic system.

The inspection terms after reliability test, as below

ITEM	Inspection
Contrast	CR>50%
IDD	IDD<200%
Brightness	Brightness>60%
Color Tone	Color Tone+/-0,05

IIDWay Technology Co. Ltd

9. Precautions for Use of LCD Modules

9.1 Handling Precautions

9.1.1 *The display panel is made of glass. Do not subject it to a mechanical shock by dropping it from a high place, etc.*

9.1.2 *If the display panel is damaged and the liquid crystal substance inside it leaks out, be sure not to get any in your mouth, if the substance comes into contact with your skin or clothes, promptly wash it off using soap and water.*

9.1.3 *Do not apply excessive force to the display surface or the adjoining areas since this may cause the color tone to vary.*

9.1.4 *The polarizer covering the display surface of the LCD module is soft and easily scratched. Handle this polarizer carefully.*

9.1.5 *If the display surface is contaminated, breathe on the surface and gently wipe it with a soft dry cloth. If still not completely clear, moisten cloth with one of the following solvents:*

— Isopropyl alcohol — Ethyl alcohol

Solvents other than those mentioned above may damage the polarizer. Especially, do not use the following:

— Water — Ketone — Aromatic solvents

9.1.6 *Do not attempt to disassemble the LCD Module.*

9.1.7 *If the logic circuit power is off, do not apply the input signals.*

9.1.8 *To prevent destruction of the elements by static electricity, be careful to maintain an optimum work environment.*

a. Be sure to ground the body when handling the LCD Modules.

b. Tools required for assembly, such as soldering irons, must be properly ground.

c. To reduce the amount of static electricity generated, do not conduct assembly and other work under dry conditions.

d. The LCD Module is coated with a film to protect the display surface. Be care when peeling off this protective film since static electricity may be generated.

IIDWay Technology Co. Ltd

9.2 Storage precautions

9.2.1 *When storing the LCD modules, avoid exposure to direct sunlight or to the light of fluorescent lamps.*

9.2.2 *The LCD modules should be stored under the storage temperature range. If the LCD modules will be stored for a long time, the recommend condition is:*

Temperature : 0°C ~ 40°C

Relatively humidity: ≤80%

9.2.3 *The LCD modules should be stored in the room without acid, alkali and harmful gas.*

9.3 *The LCD modules should be no falling and violent shocking during transportation, and also should avoid excessive press, water, damp and sunshine.*

END